

SELF-ADJUSTING TENSIONER

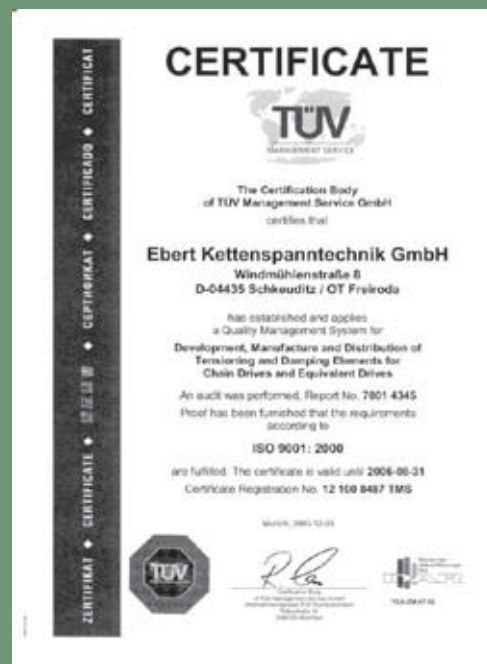

ROLL-RING®



Chain Tensioner
Chain Damper

Rolls elastically

Self-adjusting
Automatic
Reversible mode
Maintenance-free

No sprockets
One second fitment

SUPPLY SERVICES LTD



Phone 0800 102 112 - www.supplyservices.co.nz

E B E R T

KETTENSPANNTECHNIK
G m b H

Minimum structure, universal function

Novel principles in simple, elementary mechanisms are seldom in technology.

Our ROLL-RING chain tensioners are such an elementary mechanism. They are technically seen minimal mechanisms and their new principle of function is fantastically simple.

The product series on this innovation was awarded the Innovation Prize of the State of Saxony, Germany.

The ROLL-RING chain tensioners are protected by German and international patents and trademark.



elastic, inside-ventilated
tooth profile

independent of rotational direction
symmetric

polymer high performance
material

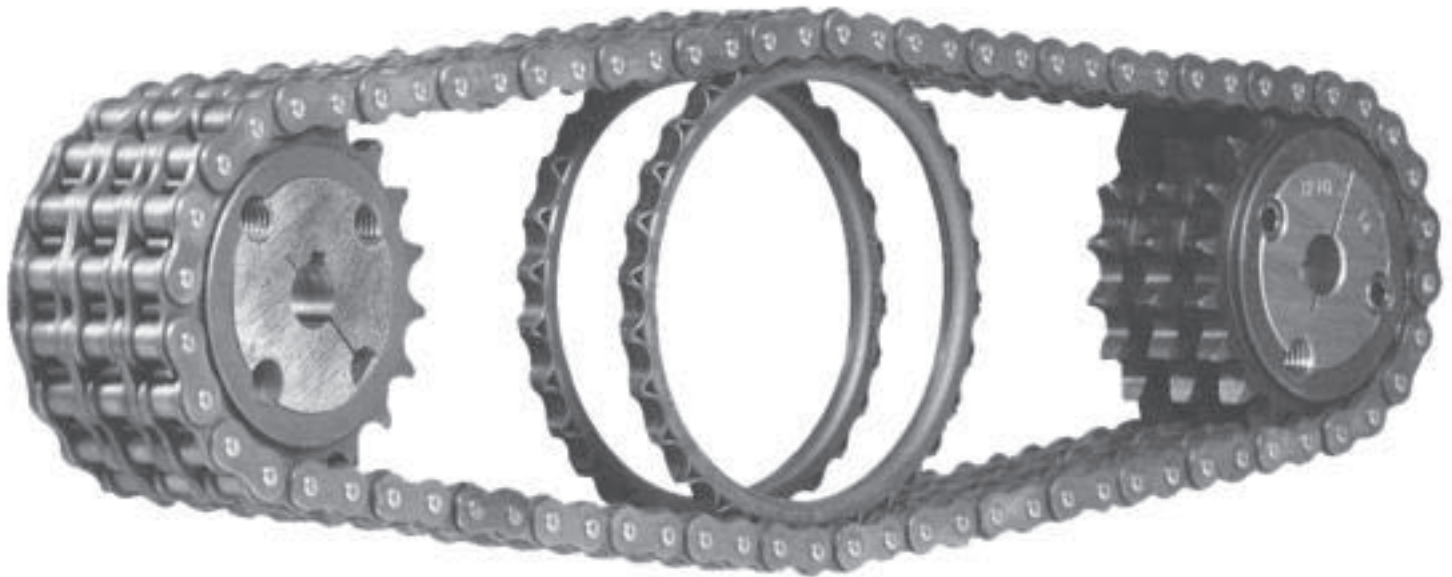

exact diametrical tension on load strand and un-load strand

The new principle:

The principle of ROLL-RING chain tensioners is based on two simple effects:

The elastic ring engages with the chain strands and rolls between them in a pre-stressed condition taking up the shape of an ellipse.

The constantly opposing movements of the load and un-load strands cancel each other out, to the "zero sum movement", thereby holding the ROLL-RING in position.

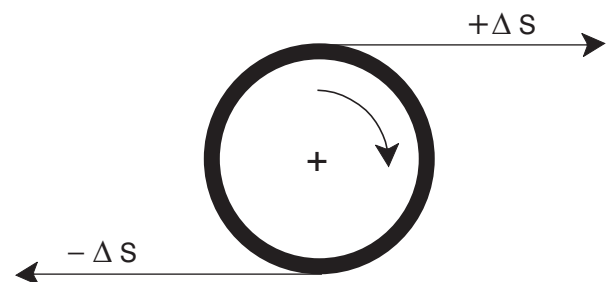

That guarantees the independent position and the reversibility of the ROLL-RING chain tensioners.

It is so easy ...

In the same time you take to read this sentence you can improve the quality of your chain drive, as ROLL-RING chain tensioners are mounted within seconds.

Normal supports as a basis for installation for chain drives, e.g. plates, struts, flanges, thread holes, ... are no longer necessary.

They are pre-tensioned manually in the shape of an ellipse without requiring any tool, positioned between the chain strands and released.

That makes them highly functional without requiring any tool and without any alignment or adjustment.

... to improve the quality of your chains.

ROLL-RING chain tensioners offer complex functional advantages, as they are chain tensioners and dampers in one.

The chain tensioner is easily installed where space limitations prohibit the use of conventional chain tensioners.

As a result of their tensioning effect on both strands the ROLL-RING chain tensioner prevents a mutual deformation of the chain elements due to overrunning impact also in the load strand and the fluctuating distances between the joints.

The chain is prevented from moving onto the tooth flanks.

The ROLL-RING chain tensioners therefore improve the chain intake and the distribution of the whole load-force onto the teeth on the sprocket.

They take effect against the total of chain drive errors resulting from assembly, the sprocket and the chain, maintenance and dynamic of the chain drive. If the cumulative error of a chain drive of average quality is reduced to about 50% as a result of using quality chains and quality sprockets, the installation of a ROLL-RING chain tensioner additionally reduces this cumulative error to about 35% [1].

That improves the precision and the life of the chain drive considerably. At the same time the noise level of the chain drive is reduced by 2 to 5 dB(A), in the critical area with regard to industrial medicine by 85 dB(A).

[1] "antriebstechnik" (drive engineering), No. 10/99, page 34

ROLL-RING chain tensioners do not require any time for maintenance or adjustment; they are automatic, always exactly diametrical and self-lubricating in chain operation.

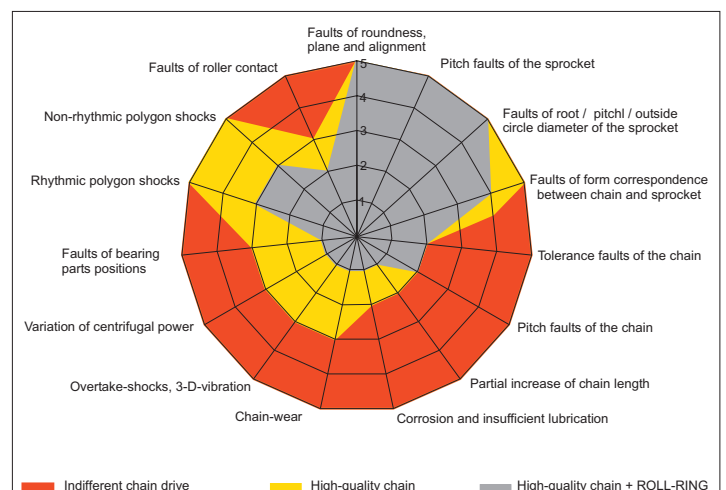
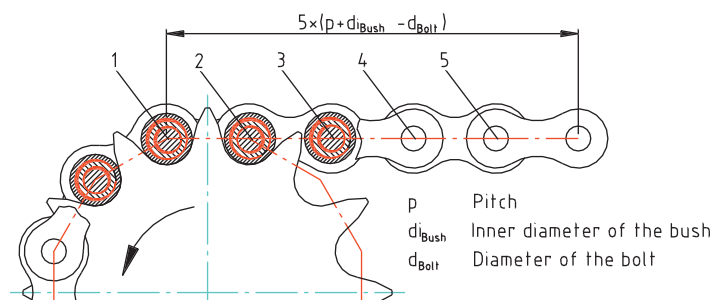
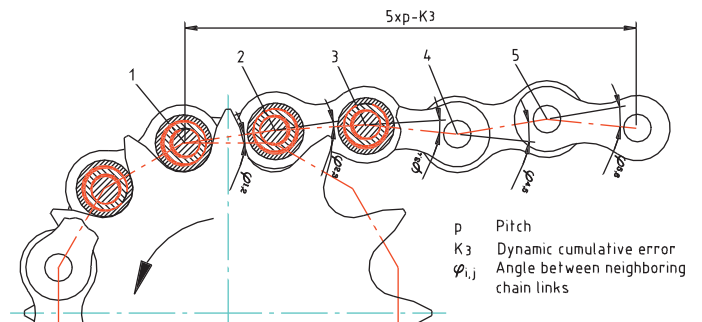
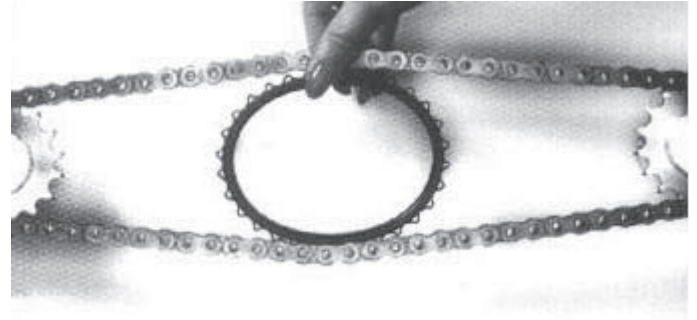

The parameters comply with the practical requirements

Via the material and the cross-sections of the rings we have set the tension required for our practical application case.

ROLL-RING chain tensioners are available for roller chains in compliance with DIN 8187, ISO 05 B-1 to ISO 20 B-1 and with ANSI Standard B29,1, No. 35 to 100.

If the chain drives with these standardized chains meet the desired installation requirements with regard to the number of teeth on the sprockets, the center distance and the number of chain elements, then you can be sure that sufficient tensing and damping as well as the reliable positioning and reversibility will be given.

ROLL-RING chain tensioners prestress the chains with static tension from the resilience of the elastic ring with additional dynamic resilience from the speed-related damping of the material.

The ROLL-RING chain tensioners provide as much tension as necessary at low chain speeds and have reserves of tensing and damping capacity for higher chain speeds.

Dynamic (1), static (2) and resulting tension (3) for ROLL-RING 112 030 01

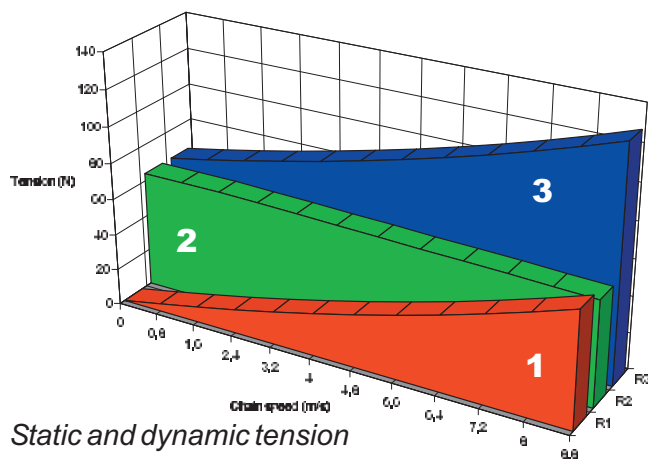

Static and dynamic tension

With regard to the chain speed all ROLL-RING chain tensioners can be used up to the maximum speed limits specified by the chain manufacturers for manual lubrication and for drip lubrication for their high-performance chains.

The laterally opened teeth on the toothed cog of the ROLL-RING chain tensioners dampen the roll impact in the chain intake.

Moreover, because of an elastic closing movement, they prevent a direct contact of the chain with the bottom area of the roll bed. This prevents a transmission of heat from the warm chain to the plastic ring.

The teeth are aired and function with increasing speed similar to a cooling fan deducting the air from chain contact.

With the material mixture and the manufacturing technology we have therefore given the ROLL-RING chain tensioners a high chemical resistance, flexibility in cold temperatures, stability in warm temperatures and stability against ultra-violet radiation.

Our product series "ROLL-RING General Mechanical Engineering" (UV stable) and ROLL-RING "Agricultural Machines/Communal Engineering" (enhanced UV stability) result from this technology.

The ROLL-RING chain tensioners are extremely resistant to wear and tear.

In permanent tensile tests the bases of technical reliability and the quality of these innovative products were realized prior to launching the product on the market in 1995.

These tests have led to products, which hardly reflect any measurable or visible wear and tear in long-year permanent operation.

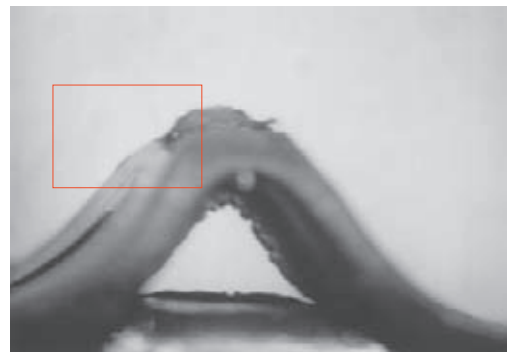

Wear and tear on the mould parting edge of a ROLL-RING 108 030 01, after 31,500 h of permanent operation on a luggage conveyor drive at the Frankfurt/Main Airport. No further wear and tear is visible.



Cut-out section of an unused comparison part from the same production batch.

In comparison with the unused ROLL-RING from the same production batch the used ROLL-RING only reflects a spring constant, which is 3.0 % higher after 31,500 operating hours due to the slightly hygroscopic material.

There are no indications to indicate the end of life as a result of wear and tear.

Fields of application

ROLL-RING chain tensioners can be applied in a wide variety of fields of mechanical engineering. They fulfill their functions in a multitude of applications.

Our regular clients comprise initial fitters and retrofitters.

ROLL-RING chain tensioners have been reliably operating in printing machines, luggage conveyor drives/transportation systems at airports, cleaning and filling systems in breweries, roller conveyors in aluminum pressing plants, but also in chain drives on vibratory plates, in automatic sand blasting machines and in agricultural machines with heavy duty chain drives, for example, dung strewers. You will find a selection of application examples on page 15.

Arrangement of ROLL-RING chain tensioners in the chain drive

ROLL-RING chain tensioners can be installed in chain drives with standard chains. Prerequisite is a working area with a strand distance which is smaller than the pitch circle of the chain tensioner and a sufficient distance between the sprockets. In any case it is necessary to exclude any contact with the sprockets even in the largest ellipse-shaped deformation.

Examples:

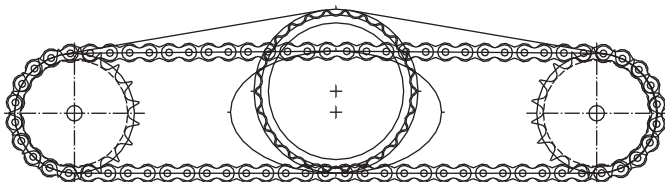

Central arrangement in chain drives with transmission ratio $i=1$.

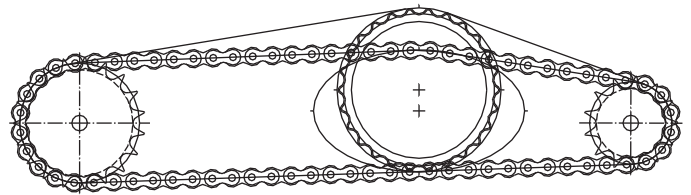

Asymmetric arrangement in chain drives with transmission ratio $i \neq 1$

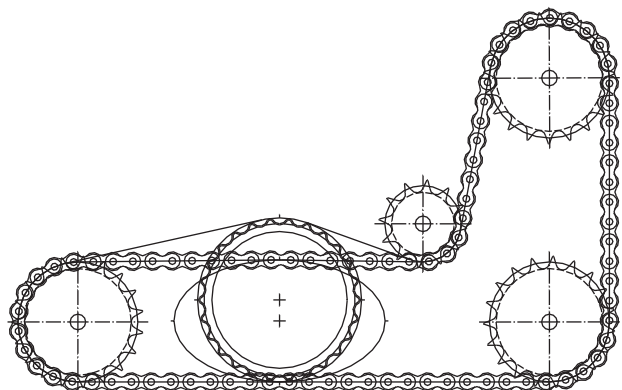

Arrangement in deflected chain drives

In multi-strand chain drives the ROLL-RING chain tensioners are arranged between the sprockets as in single-strand chain drives.

The arrangement into the chain strands is in the case of double-strand chains in every chain strand and parallel.

In treble-strand chains it is sufficient to tension only strand 1 and strand 2, if chain drives with lower axial distance are used (see photo on page 2).

If the weight of the slack strand is greater than the total tension of 2 ROLL-RING chain tensioners, then it is necessary to arrange the 3 chain tensioners in parallel.

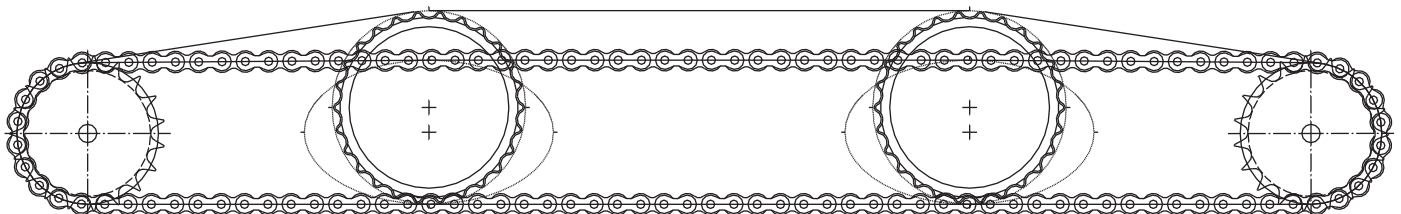

Arrangement in chain drives with larger axial distance

Selecting the type for assembly in the existing chain drive

To select the ROLL-RING type you can use our service.

We offer you a 2-year warranty for the chain tensioners for which we give you an assembly recommendation in service.

You can use our **cost-free 1-1-1 fax service** and our **cost-free 1-1-1 e-mail service** via our address <http://www.roll-ring.com>.

You receive an installation advice on working days between 8AM and 4.30PM (MET) within one hour.

All you need to do is to send us a copy of the fax form, which you will find on the rear side of this brochure. Enter some values of your chain drive and send it to us.

If you would like us to call back, offer you consulting at your company or require a delivery offer, only mark the form appropriately. We will then contact you.

In a maximum of 1 hour we will calculate the type and assembly position of the ROLL-RING chain tensioner using a CAD program.

Example for a reply:

12B-1; X=64; Z1=20; Z2=13; a=451mm, ROLL-RING 112 026 01

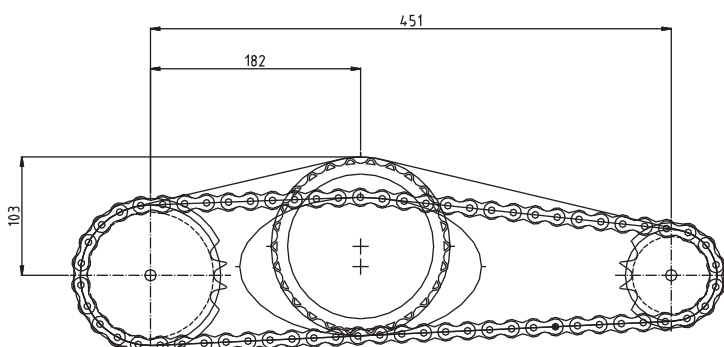

On our homepage you will find appropriate fields to enter the parameters of your chain drive and the possibility to directly send these to us by a mouse click.

Any further cases of application? Have you got a form copy for further cases of application?
Have you already got a form copy?

1 - hour - fax - service
In 60 minutes you will get your concrete installation proposal as well as an offer for your ROLL-RING chain tensioner

Ebert Kettenspanntechnik GmbH Sender:
Our fax No.: Your officer:
++49(0) 34 20 76 93 93
Our officer: Phone:
Phone: Fax:

<p>Information on chain drive (if known)</p> <p>Chain type:..... (ISO / ANSI -No.) No. of links X =</p> <p>Chain is new <input type="checkbox"/> pre-stressed <input type="checkbox"/> run-in <input type="checkbox"/></p> <p>Driving Sprocket: z1 <input type="checkbox"/> z2 <input type="checkbox"/> R.P.M. n = min</p> <p>Special environmental influence: UV-radiation <input type="checkbox"/> chemicals <input type="checkbox"/> temperatures <input type="checkbox"/> other conditions</p>	<p>Desired delivery for offer</p> <p>Do you require the delivery within 24 hours <input type="checkbox"/> within 2-3 days <input type="checkbox"/> within 5-6 days <input type="checkbox"/></p> <p>according to requirements on call as complete delivery <input type="checkbox"/></p> <p>Desired payment 14 days, 2 % discount <input type="checkbox"/> 30 days net <input type="checkbox"/> special agreement <input type="checkbox"/></p> <p>Do you desire consulting by phone <input type="checkbox"/></p>
---	--

Please complete this drawing

You will find the CAD files for the ROLL-RING product series under: <http://www.roll-ring.com>

Individual selection of the type for assembly in the existing chain drive ANSI Series

If you desire to select the ROLL-RING chain tensioner for an already existing chain drive, independent of the transmission ratio, we recommend you to proceed as follows:

Measure in the area of the intersection between the inner crossing tangents of the chain drive the widest distance of the strands which have been pulled apart, via the centers of the chain joints (e.g.: $D^* = 3.347''$).

Measure the inner width between the sprockets (e.g.: $A^* = 12.205''$)

Determine the ANSI No. of the chain (e.g. 40).

Enter with this ANSI No. in the table "Installation and final dimensions for ROLL-RING chain tensioners/series ANSI" (to the right).

Select the appropriate group in the column "ANSI No." (e.g. 40).

Specify the article group (108 026 01, 108 030 01, 108 034 01).

Check **within this article group** to determine which of the articles fulfils the following values measured by you for A^* and D^* of the chain drive:

$D^* > D$ and $D^* < d_e$ (self-holding restriction) and $A^* \geq A$ (working area restriction).

Articles fulfilling this condition are suitable for your chain drive. For example the article 108 026 01 fulfills these conditions.

This means that you have determined the matching article. If there are several types with various numbers of teeth within the article group, you should decide in favor of the article with the largest number of teeth.

The ideal assembly position is in the area of the intersection of the inner tangents.

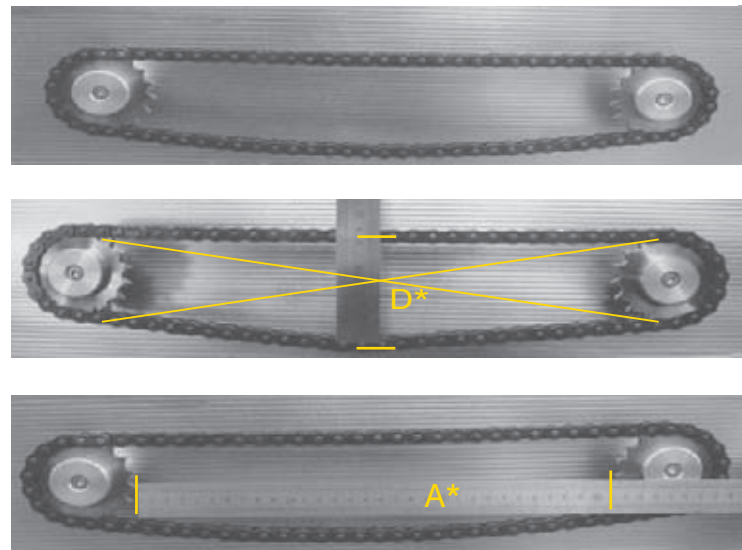

Installation and final dimensions for the ROLL-RING chain tensioner/series ANSI:

ANSI-No.	Article	d_e	d_i	s	A	$D = d_e \cdot s$
35	806 030 01	3.539	3.024	1.063	4.449	2.476
40	108 026 01	4.154	3.445	1.063	5.346	3.091
40	108 030 01	4.783	4.000	1.181	6.362	3.602
40	108 034 01	5.413	4.543	1.181	6.496	4.232
40	108 430 01	4.783	4.000	1.181	6.362	3.602
50	110 026 01	5.055	4.134	1.102	6.024	3.953
50	110 030 01	5.827	4.906	1.299	6.969	4.528
50	110 034 01	6.693	5.551	1.496	8.543	5.197
60	112 026 01	6.102	5.024	1.378	8.248	4.724
60	112 030 01	7.173	6.028	1.772	9.528	5.401
60	112 034 01	8.169	6.673	1.772	10.433	6.397
80	116 026 01	8.150	6.575	1.772	10.591	6.378
80	816 030 01	9.528	7.874	1.969	12.402	7.559
100	120 030 01	11.957	10.094	2.560	15.354	9.397

All values in inches.
Value "A" includes a safety distance to the sprockets

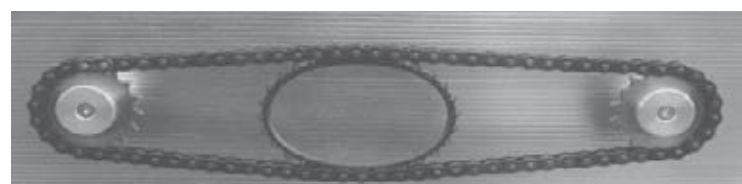
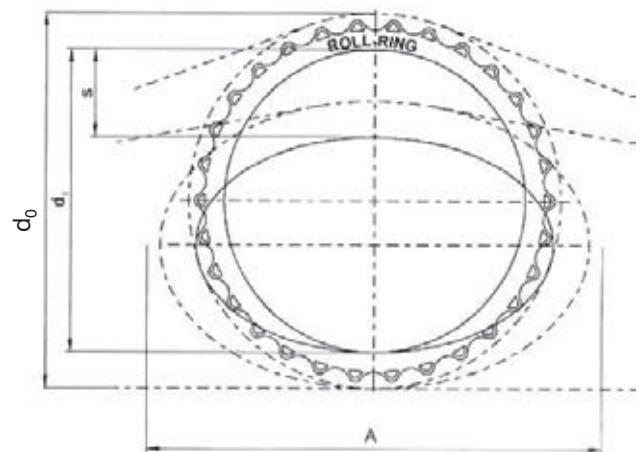

Individual selection of the type for assembly in the existing chain drive ISO B Series

If you desire to select the ROLL-RING chain tensioner for an already existing chain drive, independent of the transmission ratio, we recommend you to proceed as follows:

Measure in the area of the intersection between the inner crossing tangents of the chain drive the widest distance of the strands which have been pulled apart, via the centers of the chain joints (e.g.: $D^* = 85 \text{ mm}$).

Measure the inner width between the sprockets (e.g.: $A^* = 310 \text{ mm}$).

Determine the ISO No. of the chain (e.g. **08 B-1**).

Enter with this ISO No. in the table "Installation and final dimensions for ROLL-RING chain tensioners/series ISO B" (to the right).

Select the appropriate group in the column "ISO No." (e.g. **08 B**).

Specify the article group (108 026 01, 108 030 01, 108 034 01).

Check **within this article group** to determine which of the articles fulfils the following values measured by you for A^* and D^* of the chain drive:

$D^* > D$ and $D^* < d_o$ (self-holding restriction) and $A^* \geq A$ (working area restriction).

Articles fulfilling this condition are suitable for your chain drive. For example the article 108 026 01 fulfills these conditions.

This means that you have determined the matching article. If there are several types with various numbers of teeth within the article group, you should decide in favor of the article with the largest number of teeth.

The ideal assembly position is in the area of the intersection of the inner tangents.

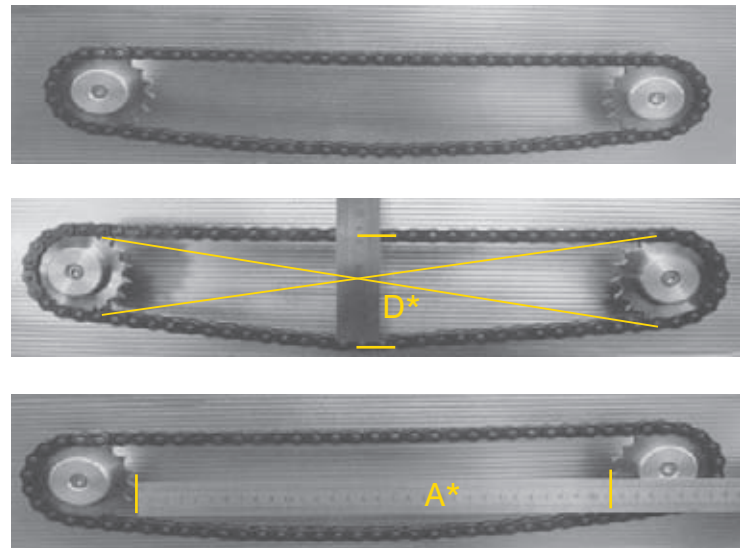

Installation and final dimensions for the ROLL-RING chain tensioner/series ISO B:

ISO-No.	Article	d_o	d_i	s	A	$D=d_o-s$
05 B	105 030 01	76.5	65.0	20.0	104.0	56.5
06 B	106 030 01	91.1	73.0	25.0	122.0	66.1
06 B	106 036 01	109.0	89.0	25.0	143.0	84.0
08 B	108 026 01	105.5	87.5	27.0	135.8	78.5
08 B	108 030 01	121.5	101.6	30.0	161.6	91.5
08 B	108 034 01	137.5	115.4	30.0	165.0	107.5
08 B	108 430 01	121.5	101.6	30.0	161.6	91.5
10 B	110 026 01	128.4	105.0	28.0	153.0	100.4
10 B	110 030 01	148.0	124.6	33.0	177.0	115.0
10 B	110 034 01	170.0	141.0	38.0	217.0	132.0
12 B	112 026 01	155.0	127.6	35.0	209.5	120.0
12 B	112 030 01	182.2	153.1	45.0	242.0	137.2
12 B	112 034 01	207.5	169.5	45.0	265.0	162.5
16 B	116 026 01	207.0	167.0	45.0	269.0	162.0
16 B	116 030 01	245.8	202.0	50.0	306.0	195.8
20 B	120 030 01	303.7	256.4	65.0	390.0	238.7

All values in mm
Value "A" includes a safety distance to the sprockets

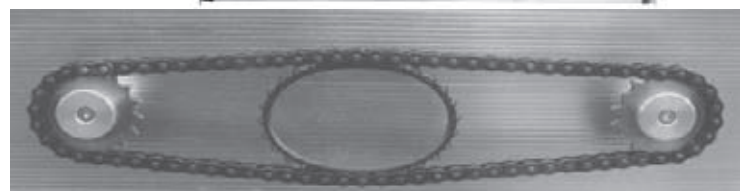
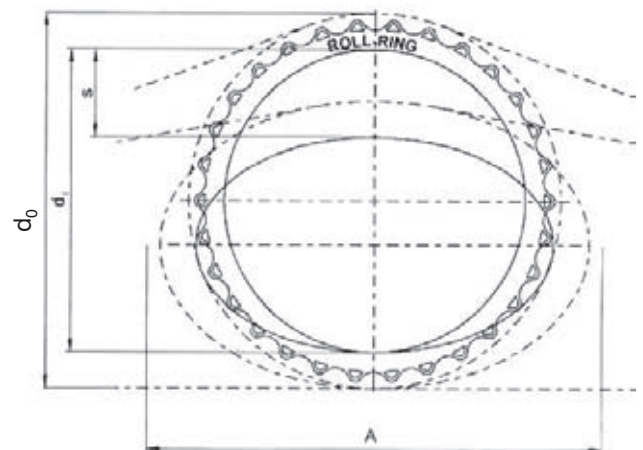

Assembly in chain drive

ROLL-RING chain tensioners can be easily installed.

They are compressed manually and inserted in this pretensioned state between the chain drive strands and then released.

This means that they are ready for operation within seconds; without requiring any tools or adjusting.

The assembly position should, if possible, lie within the area of the intersection of the inner tangents.

Other positions beyond the recommended position are also permissible, if the ROLL-RING is sufficiently pretensioned and cannot collide with the sprockets in its mounted state.

In the case of chain drives with a transmission ratio $i > 1$, $i < 1$, you can increase the tension if you shift the installation position towards the small sprocket. Practical trial and error are recommended to find the ideal setting.

Inserting the CAD files into constructions

For the ROLL-RING product series we make CAD files available free of charge. You will find these CAD files in Internet under <http://www.roll-ring.com>. All you have to do is to download these CAD files. You can then insert these into your construction to optimize your chain drive. If you have no Internet access, we can send you the CAD files on a diskette.

The delivery program

The ROLL-RING product range for the European market is based on roller-chains in compliance with DIN 8187, BS 228, ISO 05 B to ISO 20 B.

Moreover we also supply ROLL-RING chain tensioners to our direct international clients and sales partners according to the standard DIN 8188, ANSI B29.1 (roller-chain according to American standard) and according to JIS B 1801 according to Japanese industrial standard.

Please ask for the appropriate article lists, if applicable.

The ROLL-RING chain tensioners type code 01 were modified with regard to the maximally permissible chain speed, wear period, chemical resistance, thermal ageing resistance and cold flexibility.

These types can therefore be ideally applied for a wide spectrum of mechanical engineering requirements.

The ROLL-RING chain tensioners type code 06 have been modified to the requirements of higher operating temperatures.

The ROLL-RING chain tensioners type code 08 reflect an excellent cold flexibility and intensified damping characteristics. That generates an especially smooth chain operation at the start and in reversing and provides especially low chain wear during operation.

You will find the article lists for the supply program on the following pages.

The complete service 1-1-1:
1 hour installation advice
1 day to leave our stock
1 second installation

Within 1 hour industrial users will obtain an installation advice on work days between 8.00 AM and 4.30 PM (MET) by fax inquiry, comprising type specification for your chain drive.

If orders are submitted by 4.30 PM we dispatch the articles in stock (article number 01) on the date of order, by special request with express package delivery.

For the other articles we will agree on a short-term delivery schedule.

Of course, we can deliver ordered chain tensioners at any requested delivery schedule.

ROLL-RING international

For the purpose of optimum deliveries and technical support as well as personal customer service we are continuously expanding our international marketing network.

Your contact:



Phone 0800 102 112 - www.supplyservices.co.nz

Product Range General Mechanical Engineering
according to ANSI 29.1 / ISO 606 A Series / DIN 8188

valid since March - 01 - 2000

Article No. 01	Dimension	ANSI Chain-No.	Chain Dimension p x b1 (Inches)	Teeth ROLL-RING	Max. Static Expansive Force (Lbs)**	Maximum Chain Speed (ft/min)	Ambient Temperature (°F)	Weight (Lbs)
806 030 01	06 C 30	35	3/8 x 3/16	30	1.28	1024	-4 till +158	0.011
108 026 01	08 A 26	40	1/2 x 5/16	26	3.01	1476	-4 till +158	0.026
108 030 01	08 A 30	40	1/2 x 5/16	30	3.19	1693	-4 till +158	0.033
108 034 01	08 A 34	40	1/2 x 5/16	34	4.94	1732	-4 till +158	0.053
108 430 01	*	*	1/2 x 3/4/6mm	30	3.78	1476	-4 till +158	0.035
110 026 01	10 A 26	50	5/8 x 3/8	26	6.34	827	-4 till +158	0.055
110 030 01	10 A 30	50	5/8 x 3/8	30	5.17	1732	-4 till +158	0.066
110 034 01	10 A 34	50	5/8 x 3/8	34	10.14	1732	-4 till +158	0.121
112 026 01	12 A 26	60	3/4 x 1/2	26	8.81	1063	-4 till +158	0.099
112 030 01	12 A 30	60	3/4 x 1/2	30	7.24	1220	-4 till +158	0.115
112 034 01	12 A 34	60	3/4 x 1/2	34	15.84	1260	-4 till +158	0.212
116 026 01	16 A 26	80	1 x 5/8	26	21.51	1122	-4 till +158	0.254
816 030 01	16 A 30	80	1 x 5/8	30	23.15	1299	-4 till +158	0.348
120 030 01	20 A 30	100	1 1/4 x 3/4	30	18.09	1378	-4 till +140	0.514

(enhanced warmth-resistant)

Article No. 06	Dimension	ANSI Chain-No.	Chain Dimension p x b1 (Inches)	Teeth ROLL-RING	Max. Static Expansive Force (Lbs)**	Maximum Chain Speed (ft/min)	Ambient Temperature (°F)	Weight (Lbs)
806 030 06	06 C 30	35	3/8 x 3/16	30	1.71	886	+18 till+ 176	0.011
108 026 06	08 A 26	40	1/2 x 5/16	26	5.42	1004	+18 till+ 176	0.026
108 030 06	08 A 30	40	1/2 x 5/16	30	7.60	1142	+18 till+ 176	0.033
108 430 06	*	*	1/2 x 3/4/6mm	30	5.89	1004	+18 till+ 176	0.035
110 026 06	10 A 26	50	5/8 x 3/8	26	8.65	728	+18 till+ 176	0.055
110 030 06	10 A 30	50	5/8 x 3/8	30	7.69	1102	+18 till+ 176	0.066
112 026 06	12 A 26	60	3/4 x 1/2	26	10.09	689	+18 till+ 176	0.099
112 030 06	12 A 30	60	3/4 x 1/2	30	13.53	787	+18 till+ 176	0.115
116 026 06	16 A 26	80	1 x 5/8	26	31.42	689	+18 till+ 176	0.254
816 030 06	16 A 30	80	1 x 5/8	30	26.52	827	+18 till+ 176	0.348

(enhanced cold-flexible)

Article No. 08	Dimension	ANSI Chain-No.	Chain Dimension p x b1 (Inches)	Teeth ROLL-RING	Max. Static Expansive Force (Lbs)**	Maximum Chain Speed (ft/min)	Ambient Temperature (°F)	Weight (Lbs)
806 030 08	06 C 30	35	3/8 x 3/16	30	0.76	1457	-22 till+122	0.011
108 026 08	08 A 26	40	1/2 x 5/16	26	2.05	1732	-22 till+122	0.026
108 030 08	08 A 30	40	1/2 x 5/16	30	2.88	2008	-22 till+122	0.033
108 430 08	*	*	1/2 x 3/4/6mm	30	2.81	1575	-22 till+122	0.035
110 026 08	10 A 26	50	5/8 x 3/8	26	3.53	906	-22 till+122	0.055
110 030 08	10 A 30	50	5/8 x 3/8	30	4.49	1988	-22 till+122	0.066
112 026 08	12 A 26	60	3/4 x 1/2	26	7.53	1083	-22 till+122	0.099
112 030 08	12 A 30	60	3/4 x 1/2	30	12.47	1260	-22 till+122	0.115
116 026 08	16 A 26	80	1 x 5/8	26	12.23	1319	-22 till+122	0.254
816 030 08	16 A 30	80	1 x 5/8	30	19.78	1339	-22 till+122	0.348

* universal for chain width of 1/8" to 5/16"

** on 68 °F and maximum tensioning deformation;

without dynamic tensioning force proportional to the chain speed

This information is based on our current knowledge and experiences.

The user is not released from own trials and experiences due to possible application-specific requirements.

Changes concerning technical development are reserved.

