

SUPPLY SERVICES

performance engineering products

SPROCKET INFORMATION GUIDE

MILL CHAIN SPROCKETS

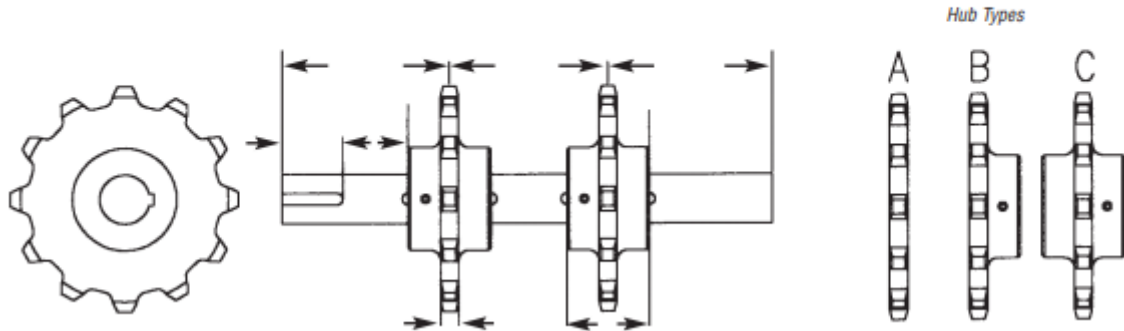

Chain Number	Number of Teeth	Pitch Dia.	Max. Bore	Tooth Face
WR-78, H-78	7	6.01	2 3/16	1
MOH-578*	8	6.82	2 7/16	1
SS-578*	9	7.63	2 11/16	1
MS-88*	10	8.44	2 15/16	1
MO-88*	11	9.26	3 7/16	1
LXS-882*	12	10.08	3 7/16	1
81-X*	13	10.90	3 15/16	1
C-188*	14	11.72	4 15/16	1
PITCH=2.609"	15	12.55	4 15/16	1
	16	13.37	4 15/16	1
	17	14.20	4 15/16	1
	18	15.02	4 15/16	1
	19	15.85	4 15/16	1
	20	16.88	5 15/16	1

Chain Number	Number of Teeth	Pitch Dia.	Max. Bore	Tooth Face
WR-78XHD	7	6.01	2 3/16	1
PITCH=2.609"	8	6.82	2 7/16	1
	9	7.63	2 11/16	1
	10	8.44	2 15/16	1
	11	9.26	3 7/16	1
	12	10.08	3 7/16	1
	13	10.90	3 15/16	1
	14	11.72	4 15/16	1
	15	12.55	4 15/16	1
	16	13.37	4 15/16	1
	17	14.20	4 15/16	1
	18	15.02	4 15/16	1
	19	15.85	4 15/16	1
	20	16.88	5 15/16	1

* Tooth face is 7/8"

Most flame cut sprockets supplied from stock.

Chain Number	Number of Teeth	Pitch Dia.	Max. Bore	Tooth Face
WR-82 PITCH=3.075'	7	7.09	2 7/16	1 1/8
	8	8.04	3 15/16	1 1/8
	9	8.99	4 15/16	1 1/8
	10	9.95	5 7/16	1 1/8
	11	10.91	5 15/16	1 1/8
	12	11.88	5 15/16	1 1/8
	13	12.85	5 15/16	1 1/8
	14	13.82	5 15/16	1 1/8
	15	14.79	5 15/16	1 1/8
	16	15.76	5 15/16	1 1/8
	17	16.73	5 15/16	1 1/8
	18	17.71	5 15/16	1 1/8
	20	19.66	5 15/16	1 1/8
WR-82XHD	7	7.09	2 7/16	1 1/8
WRC-131 *	8	8.04	3 15/16	1 1/8
C-131	9	8.99	4 15/16	1 1/8
PITCH 3.075	10	9.95	5 7/16	1 1/8
	11	10.91	5 15/16	1 1/8
	12	11.88	5 15/16	1 1/8
	13	12.85	5 15/16	1 1/8
	14	13.82	5 15/16	1 1/8
	15	14.79	5 15/16	1 1/8
	16	15.76	5 15/16	1 1/8
	17	16.73	5 15/16	1 1/8
	18	17.71	5 15/16	1 1/8
	20	19.66	5 15/16	1 1/8



Chain Number	Number of Teeth	Pitch Dia.	Max. Bore	Tooth Face
H-130/138	6	8.00	2 7/16	1
WR-78-4	7	9.22	3 7/16	1
PITCH=4.000*	8	10.45	4 15/16	1
	9	11.70	5 15/16	1
	10	12.94	5 15/16	1
	11	14.20	5 15/16	1
	12	15.45	5 15/16	1
	16	20.50	5 15/16	1
WR-124	6	8.00	2 7/16	1 1/2
C-102B	7	9.22	2 15/16	1 1/2
PITCH=4.000*	8	10.45	3 7/16	1 1/2
	9	11.66	3 15/16	1 1/2
	10	12.94	4 15/16	1 1/2
	11	14.20	4 15/16	1 1/2
	12	15.46	4 15/16	1 1/2
	13	16.72	5 15/16	1 1/2
	14	17.98	5 15/16	1 1/2
	15	19.23	5 15/16	1 1/2
	16	20.50	5 15/16	1 1/2
	18	23.04	5 15/16	1 1/2
	20	25.57	5 15/16	1 1/2
WR-106	6	12.00	4 15/16	1 1/2
PITCH=6.000	8	15.68	4 15/16	1 1/2
	9	17.54	5 15/16	1 1/2
	10	19.42	5 15/16	1 1/2
	11	21.30	5 15/16	1 1/2
	12	23.18	5 15/16	1 1/2
	13	25.07	5 15/16	1 1/2
WR-106XHD	6	12.00	4 15/16	1 1/2
PITCH=6.050	8	15.68	4 15/16	1 1/2
	9	17.54	5 15/16	1 1/2
	10	19.42	5 15/16	1 1/2
	11	21.30	5 15/16	1 1/2
	12	23.18	5 15/16	1 1/2
	13	25.07	5 15/16	1 1/2

Most flame cut sprockets, finished bore K+S.S. or T.K. are supplied from stock. Hardened sprockets also available.

Chain Number	Number of Teeth	Pitch Dia.	Max. Bore	Tooth Face
WR-124HD	7	9.36	2 7/16	1 1/2
WR-124XHD	8	10.62	3 15/16	1 1/2
PITCH=4.063"	9	11.88	4 15/16	1 1/2
	10	13.15	5 7/16	1 1/2
	11	14.42	5 15/16	1 1/2
	12	15.70	5 15/16	1 1/2
	13	16.98	5 15/16	1 1/2
	14	18.26	5 15/16	1 1/2
	15	19.54	5 15/16	1 1/2
	16	20.83	5 15/16	1 1/2
	17	22.11	5 15/16	1 1/2
	18	23.40	5 15/16	1 1/2
	20	25.97	5 15/16	1 1/2
WR-111	8	12.44	4 15/16	2
PITCH=4.760"	9	13.91	4 15/16	2
	10	15.40	4 15/16	2
	11	16.90	5 15/16	2
	12	18.39	5 15/16	2
	13	19.89	5 15/16	2
	14	21.39	5 15/16	2
	16	24.40	5 15/16	2
	17	25.90	5 15/16	2
	18	27.41	5 15/16	2
	20	30.43	5 15/16	2
	24	36.47	5 15/16	2
	26	39.49	5 15/16	2
	28	42.51	5 15/16	2
WR-132	8	15.81	5 15/16	2 3/4
WRC-132	9	17.69	6 15/16	2 3/4
WR-132XHD	10	19.58	6 15/16	2 3/4
WRC-132XHD	11	21.47	6 15/16	2 3/4
WR/WH-157	12	23.38	6 15/16	2 3/4
WH-200	13	25.28	6 15/16	2 3/4
WR-150	14	27.19	6 15/16	2 3/4
WR-155	15	29.10	6 15/16	2 3/4
WR-159	16	31.01	6 15/16	2 3/4
PITCH=6.050"	18	34.84	6 15/16	2 3/4



LONG LINK SPROCKETS available in fabricated steel and cast steel.

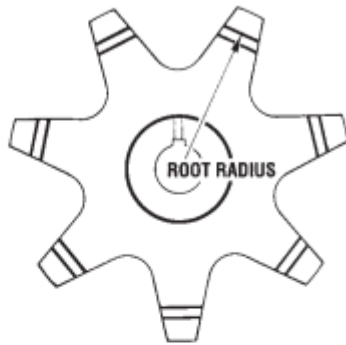

LONG LINK IDLERS are available with fabricated steel center, cast steel center or manganese center groove.

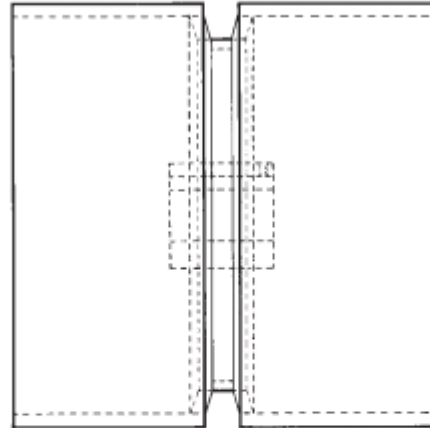

	Chain Size	Horizontal Pitch Diameter	Tooth Face
5 TOOTH	3/4 x 1 1/2 x 6	18.205	1 1/4
	7/8 x 1 1/2 x 6	18.158	1 1/4
	1 x 1 1/2 x 6	18.111	1 1/4
	* 1 x 1 3/4 x 6	18.111	1 1/2
	* 1 1/8 x 2 x 6	18.062	1 1/2
	1 1/4 x 2 x 6	18.012	1 3/4
	1 1/4 x 2 x 8	24.180	1 3/4
	1 1/2 x 2 1/4 x 8	24.082	2
6 TOOTH	3/4 x 1 1/2 x 6	22.177	1 1/4
	7/8 x 1 1/2 x 6	22.140	1 1/4
	1 x 1 1/2 x 6	22.100	1 1/4
	* 1 x 1 3/4 x 6	22.100	1 1/2
	* 1 1/8 x 2 x 6	22.060	1 1/2
	1 1/4 x 2 x 6	22.019	1 3/4
	1 1/4 x 2 x 8	29.493	1 3/4
	1 1/2 x 2 1/4 x 8	29.413	2
7 TOOTH	3/4 x 1 1/2 x 6	26.105	1 1/4
	7/8 x 1 1/2 x 6	26.072	1 1/4
	1 x 1 1/2 x 6	26.039	1 1/4
	* 1 x 1 3/4 x 6	26.039	1 1/2
	* 1 1/8 x 2 x 6	26.005	1 1/2
	1 1/4 x 2 x 6	25.970	1 3/4
	1 1/4 x 2 x 8	34.741	1 3/4
	1 1/2 x 2 1/4 x 8	34.673	2

Diameter	Face	Stock	Diameter	Face	Stock
14	12	1/2	24	14	1/2
14	14	1/2	24	16	1/2
14	16	1/2	24	18	1/2
14	18	1/2	24	20	1/2
14	20	1/2	24	22	1/2
16	12	1/2	24	24	1/2
16	14	1/2	24	26	1/2
16	16	1/2	24	28	1/2
16	18	1/2	24	30	1/2
16	20	1/2	30	16	1/2
18	14	1/2	30	18	1/2
18	16	1/2	30	20	1/2
18	18	1/2	30	22	1/2
18	20	1/2	30	24	1/2
18	22	1/2	30	26	1/2
18	24	1/2	30	28	1/2
20	14	1/2	30	30	1/2
20	16	1/2			
20	18	1/2			
20	20	1/2			
20	22	1/2			
20	24	1/2			

Any diameter or width can be furnished with any size hub or bore. All sizes in inches. Specify chain size when ordering.

For longer chain life use 7 tooth pattern.
*Denotes most common chain sizes.



SPROCKETS FOR RIVETLESS CHAIN are normally supplied in fabricated high-carbon steel.
Available in Solid, Split, Removable Rim or Split Removable Rim.

Solid

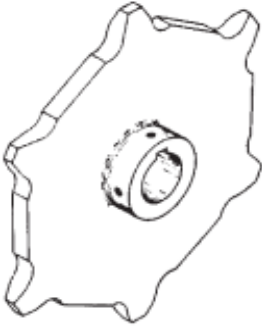

Chain	Teeth	Pitch Diameter	
458/X-458	3	8.00	
	4	10.45	
	5	12.94	
	6	15.45	
	7	17.97	
	8	20.50	
	9	23.03	
	678/X-678	4	15.68
		5	19.41
6		23.18	
7		26.96	
8		30.75	
9		34.56	
698		4	15.68
		5	19.41
		6	23.18
	7	26.96	
	8	30.75	
	9	34.56	

Removable Rim

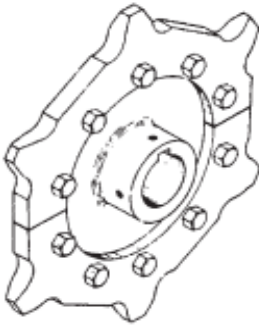

WE CAN MAKE YOUR SPECIAL SPROCKETS

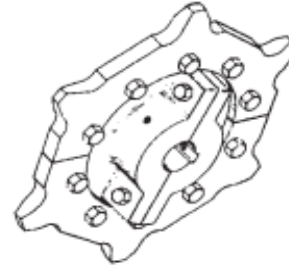

Split Bolted Segmental Rim Sprocket

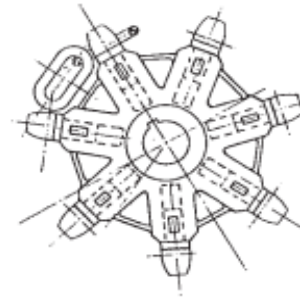

Special Sprocket Drive and Head Shaft Assemblies

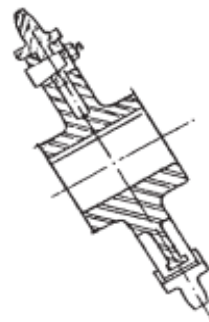
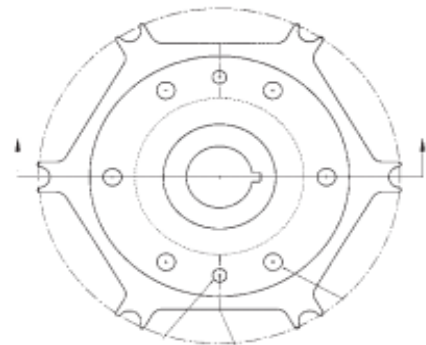
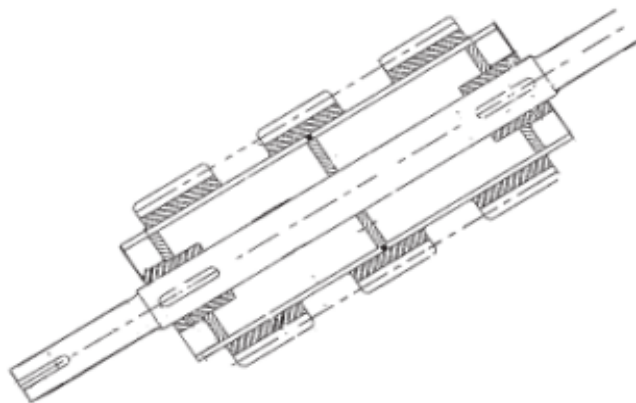

Replaceable Tooth
Cast Steel Long
Link Chain
Sprocket

CDM SYSTEMS SPROCKETS

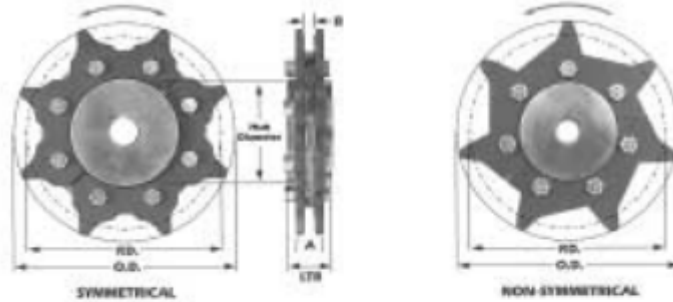

	Tooth/Bolt	P.D.	O.D.	Chain O.D.	A	B	Max Bore	Hub Dia.	LTB	Weight
102 Series *Sym. Only	6TS/6B	8.03" 204mm	8.50 216	9.375 238	1.375 35	.50 12.7	2.4375 62	3.375 86	2.250 57	13 lbs 5.9 kg
	8TS/8B	10.49" 266mm	11.00 280	11.625 295	1.375 35	.50 12.7	3.4375 87	5.25 133	2.25 57	30 lbs 13.65 kg
	10TS/10B	12.99" 330mm	13.50 343	14.375 365	1.375 35	.50 12.7	3.9375 100	7.50 190	2.25 57	50 lbs 22.7 kg
	6TS/6B	11.18" 284mm	11.8 300	13.25 337	1.97 50	.67 17	3.0 76.2	4.25 108	2.75 70	35 lbs 15.90 kg
142 STD Series *Sym.	7TS/7B	12.88" 327mm	13.5 343	15.0 381	1.97 50	.67 17	3.9375 100	5.875 149.2	2.75 70	50 lbs 22.73 kg
	8TS/8B	14.6" 371mm	15.25 387	16.69 424	1.97 50	.67 17	5.75 146	7.87 200	2.75 70	84 lbs 38.18 kg
	9TS/9B	16.35" 415mm	17.0 432	18.43 468	1.97 50	.67 17	5.75 146	7.87 200	2.75 70	87 lbs 39.55 kg
	10TS/10B	18.09" 459mm	19.25 489	20.19 513	1.97 50	.67 17	6.50 165	9.50 241	2.75 70	140 lbs 63.64 kg
	11TS/11B	19.84" 504mm	21.06 535	21.94 557	1.97 50	.67 17	7.0 178	11.0 279	3.15 80	165 lbs 75 kg
	14TS/14B	25.12" 638mm	26.37 670	27.24 692	1.97 50	.67 17	7.0 178	11.0 279	4.72 120	255 lbs 115.90 kg
	6TN/6B	11.18" 284mm	11.8 300	13.25 337	1.97 50	.67 17	3.0 76.2	4.25 108	2.75 70	35 lbs 15.90 kg
142 STD Series **Non Sym.	7TN/7B	12.88" 327mm	13.5 343	15.0 381	1.97 50	.67 17	3.9375 100	5.875 149.2	2.75 70	50 lbs 22.73 kg
	8TN/8B	14.6" 371mm	15.25 387	16.69 424	1.97 50	.67 17	5.75 146	7.87 200	2.75 70	84 lbs 38.18 kg
	9TN/9B	16.35" 415mm	17.0 432	18.43 468	1.97 50	.67 17	5.75 146	7.87 200	2.75 70	87 lbs 39.55 kg
	10TN/10B	18.09" 459mm	19.25 489	20.19 513	1.97 50	.67 17	6.50 165	9.50 241	2.75 70	140 lbs 63.64 kg
	11TN/11B	19.84" 504mm	21.06 535	21.94 557	1.97 50	.67 17	7.0 178	11.0 279	3.15 80	165 lbs 75 kg
	14TN/14B	25.12" 638mm	26.37 670	27.24 692	1.97 50	.67 17	7.0 178	11.0 279	4.72 120	255 lbs 115.90 kg
	7TS/7B	12.88" 327mm	13.5 343	15.0 381	2.75 70	.75 19.05	3.9375 100	5.875 149.2	3.54 90	80 lbs 36.4 kg
142 HVY Series *Sym.	8TS/8B	14.6" 371mm	15.25 387	16.69 424	2.75 70	.75 19.05	5.75 146	7.87 200	3.54 90	98 lbs 44.55 kg
	9TS/9B	16.35" 415mm	17.0 432	18.43 468	2.75 70	.75 19.05	5.75 146	7.87 200	3.54 90	119 lbs 54.09 kg
	10TS/10B	18.09" 459mm	19.25 489	20.19 513	2.75 70	.75 19.05	6.50 165	9.50 241	3.54 90	164 lbs 74.55 kg
	11TS/11B	19.84" 504mm	21.06 535	21.94 557	2.75 70	.75 19.05	7.0 178	11.0 279	3.54 90	210 lbs 95.45 kg
	14TS/14B	25.12" 638mm	26.37 670	27.24 692	2.75 70	.75 19.05	7.0 178	11.0 279	4.72 120	320 lbs 145.45 kg
	7TN/7B	12.88" 327mm	13.5 343	15.0 381	2.75 70	.75 19.05	3.9375 100	5.875 149.2	3.54 90	80 lbs 36.4 kg
	142 HVY Series **Non Sym.	8TN/8B	14.6" 371mm	15.25 387	16.69 424	2.75 70	.75 19.05	5.75 146	7.87 200	3.54 90
9TN/9B		16.35" 415mm	17.0 432	18.43 468	2.75 70	.75 19.05	5.75 146	7.87 200	3.54 90	119 lbs 54.09 kg
10TN/10B		18.09" 459mm	19.25 489	20.19 513	2.75 70	.75 19.05	6.50 165	9.50 241	3.54 90	164 lbs 74.55 kg
11TN/11B		19.84" 504mm	21.06 535	21.94 557	2.75 70	.75 19.05	7.0 178	11.0 279	3.54 90	210 lbs 95.45 kg
14TN/14B		25.12" 638mm	26.37 670	27.24 692	2.75 70	.75 19.05	7.0 178	11.0 279	4.72 120	320 lbs 145.45 kg
6TN/6B		13.78" 350mm	14.0 356	16.14 410	2.44 62	1.18 30	4.9375 125	7.28 185	4.72 120	105 lbs 47.73 kg
175 STD Series **Non Sym. Only		8TN/8B	17.99" 457mm	18.25 464	20.35 517	2.44 62	1.18 30	6.5 165	10.0 254	4.72 120
	10TN/10B	22.28" 566mm	22.6 574	24.65 626	2.44 62	1.18 30	9.0 228.6	13.5 343	4.72 120	305 lbs 138.6 kg

*Sym. = Symmetrical **Non-Sym. = Non Symmetrical



TERMINAL & SPLIT RIM IDLERS

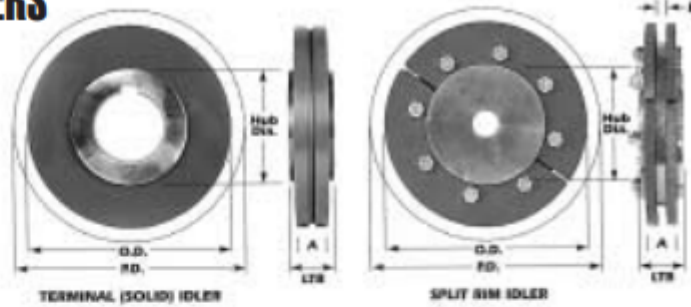

	Idler Size	Idler O.D.	P.D	Chain O.D.	A	Hub Diameter	LTB	Max Bore	Bolts Req'd	Weight
102 Series Solid Only	145	5.70" 145mm	8.00 203	9.375 238	1.25 31.75	QD	1.25 31.75	2.625 66.7	–	10 lbs 4.5 kg
	213	8.40" 213mm	10.48 266	11.625 295	1.25 31.75	QD	1.25 31.75	2.625 66.7	–	20 lbs 9.1 kg
	277	10.90" 277mm	12.83 326	14.17 360	1.25 31.75	QD	1.25 31.75	2.625 66.7	–	30 lbs 13.6 kg
142 STD Solid	198	7.80" 198mm	11.25 286	13.39 340	1.97 50	4.72 120	2.36 60	2.94 75	–	25 lbs 11.4 kg
	289	11.375" 289mm	14.49 368	16.61 422	1.97 50	7.087 180	2.75 70	3.94 100	–	63 lbs 28.6 kg
	321	12.625" 321mm	15.63 397	17.76 451	1.97 50	7.087 180	2.75 70	3.94 100	–	75 lbs 34.1 kg
	345	13.58" 345mm	16.54 420	18.66 474	1.97 50	9.45 240	3.15 80	6.50 165	–	100 lbs 45.5 kg
	437	17.20" 437mm	19.96 507	22.09 561	1.97 50	9.45 240	3.15 80	6.50 165	–	150 lbs 68.2 kg
	557	21.93" 557mm	24.53 623	26.65 677	1.97 50	8.0 203	4.0 102	6.50 165	–	245 lbs 111.4 kg
142 STD Series Split Rim	289 SR	11.375" 289mm	14.49 368	16.61 422	1.97 50	7.87 200	2.75 70	3.94 100	8	63 lbs 28.6 kg
	321 SR	13.625" 321mm	15.63 397	17.76 451	1.97 50	7.87 200	2.75 70	3.94 100	8	75 lbs 34.1 kg
	345 SR	13.58" 345mm	16.54 420	18.66 474	1.97 50	7.87 200	2.75 70	6.50 165	8	100 lbs 45.5 kg
	437 SR	17.20" 437mm	19.96 507	22.09 561	1.97 50	9.50 241	2.75 70	6.50 165	10	150 lbs 68.2 kg
	577 SR	21.93" 557mm	24.53 623	26.65 677	1.97 50	11.0 279	3.15 80	6.50 165	11	245 lbs 111.4 kg
142 HVY Series Solid	198	7.80" 198mm	11.25 286	13.39 340	2.75 70	–	2.75 70	2.94 75	–	35 lbs 15.9 kg
	289	11.375" 289mm	14.49 368	16.61 422	2.75 70	–	2.75 70	3.94 100	–	75 lbs 34.1 kg
	321	12.625" 321mm	15.63 397	17.76 451	2.75 70	–	2.75 70	3.94 100	–	95 lbs 43.2 kg
	345	13.58" 345mm	16.54 420	18.66 474	2.75 70	9.45 240	3.15 80	6.50 165	–	110 lbs 50 kg
	437	17.20" 437mm	19.96 507	22.09 561	2.75 70	9.45 240	3.15 80	6.50 165	–	185 lbs 84.1 kg
	557	21.93" 557mm	24.53 623	26.65 677	2.75 70	8.0 203	4.0 102	6.50 165	–	305 lbs 138.6 kg
142 HVY Series Split Rim	289 SR	11.375" 289mm	14.49 368	16.61 422	2.75 70	7.87 200	2.75 70	3.94 100	8	75 lbs 34.1 kg
	321 SR	12.625" 321mm	15.63 397	17.76 451	2.75 70	7.87 200	2.75 70	3.94 100	8	95 lbs 43.2 kg
	345 SR	13.58" 345mm	16.54 420	18.66 474	2.75 70	7.87 200	2.75 70	6.50 165	8	110 lbs 50 kg
	437 SR	17.20" 437mm	19.96 507	22.09 561	2.75 70	9.50 241	2.75 70	6.50 165	10	185 lbs 84.1 kg
	557 SR	21.93" 557mm	24.53 623	26.65 677	2.75 70	11.0 279	3.15 80	6.50 165	11	305 lbs 138.6 kg
175 STD Series Solid Only	243	9.567" 243mm	13.779 350	16.14 410	2.84 72	7.28 185	3.54 90	4.9375 125	–	80 lbs 36.4 kg
	362	14.252" 362mm	17.992 457	20.35 517	2.84 72	10.0 254	3.54 90	6.5 165	–	175 lbs 79.6 kg
	479	18.858" 479mm	22.283 566	24.65 626	2.84 72	13.5 343	3.54 90	9.0 228.6	–	295 lbs 134.1 kg