



Stock shapes

*Machining Recommendations
for Semi-Finished Engineering Plastics*

Content

- 4 **Processing of plastics (introduction)**
- 5 Differences between plastics and metals
- 6 Extrusion technology
- 6 Tools and machines

- 7 **Machining**
- 8 Cutting
- 9 Turning
- 9 Milling
- 10 Drilling
- 11 Cutting threads
- 11 Planing / Plane milling
- 12 Grinding
- 13 Surface quality, reworking and de-burring
- 15 Machining guidelines

- 16 **Interview with Hufschmied Zerspanungssysteme**

- 18 **Cooling and cooling lubricants**

- 19 **Annealing**
- 20 Morphological changes and post-shrinkage
- 21 Dimensional stability

- 22 **Product groups and material characteristics**
- 22 TECAFORM AH / AD, TECAPET, TECAPEEK
- 22 TECAST T, TECAMID 6, TECAMID 66
- 23 TECANAT, TECASON, TECAPEI
- 23 TECA Materials with PTFE
- 23 TECASINT
- 24 Fibre reinforced materials
- 25 Special case of TECATEC

- 26 **Machining errors - causes and solutions**
- 26 Cutting and sawing
- 26 Turning and milling
- 27 Drilling

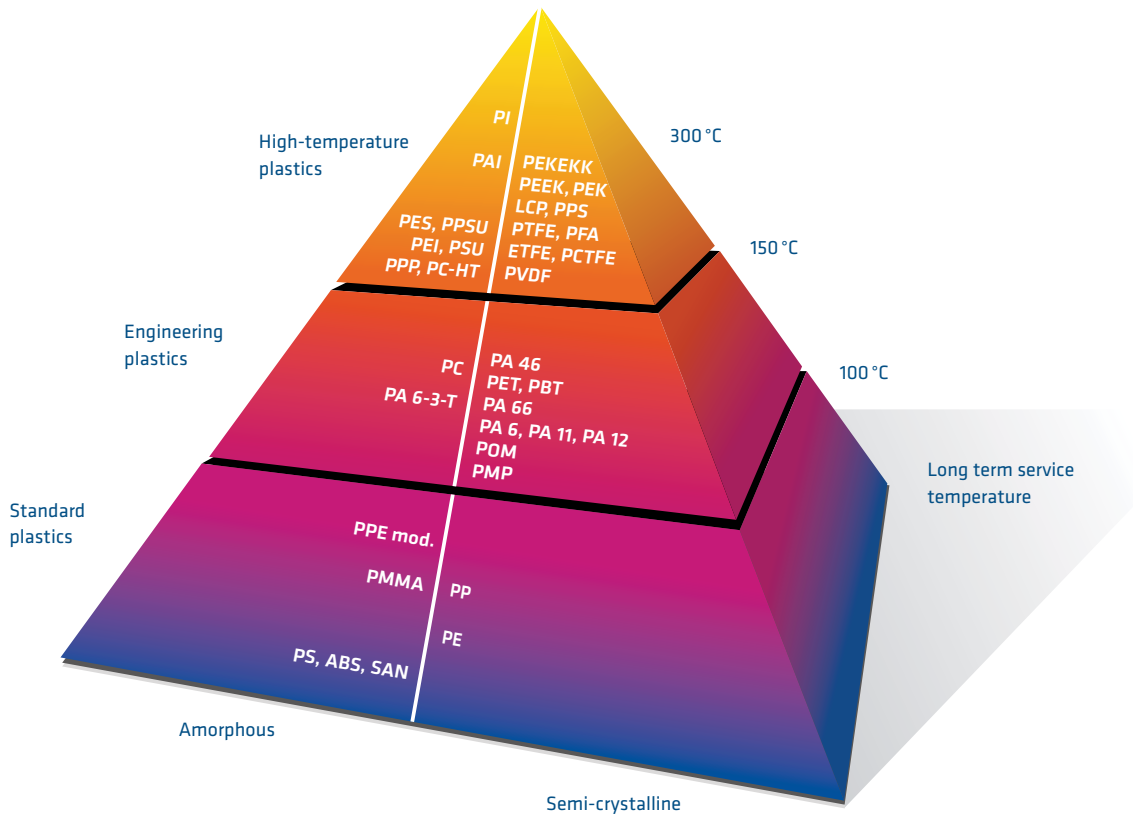

Polymer Abbreviation	Ensinger Nomenclature	Polymer Name
PI	TECASINT	Polyimide
PEEK	TECAPEEK	Polyether ether ketone
PPS	TECATRON	Polyphenylene sulphide
PPSU	TECASON P	Polyphenylsulphone
PES	TECASON E	Polyethersulphone
PEI	TECAPEI	Polyetherimide
PSU	TECASON S	Polysulphone
PTFE	TECAFLON PTFE	Polytetrafluoroethylene
PVDF	TECAFLON PVDF	Polyvinylidene fluoride
PA 6 C	TECAST T	Polyamide 6 cast
PA 66	TECAMID 66	Polyamide 66
PA 6	TECAMID 6	Polyamide 6
PC	TECANAT	Polycarbonate
PBT	TECADUR PBT	Polybutylene terephthalate
PET	TECAPET	Polyethylene terephthalate
PPE	TECANYL	Polyphenylene ether
POM-C	TECAFORM AH	Polyoxymethylene Copolymer
POM-H	TECAFORM AD	Polyoxymethylene Homopolymer
PMP	TECAFINE PMP	Polymethylpentene



Processing of plastics

Dimensionally stable, functional and durable components can be manufactured from plastics using professional machining and processing techniques. The general term “Plastic Processing” suggests that all plastics can be machined with the same parameters and tools. With metals, on the other hand, one speaks not only of “metal processing”, but a difference is made between aluminium, steel or stainless steel. In an analogous way, it applies that the individual characteristics of plastic materials have to be taken into consideration when processing them.

The specific properties of plastics have a decisive influence upon their machining ability. Materials can be classified into different groups:

- Amorphous thermoplastics
(e.g.: TECASON S, TECANAT)
- Partly crystalline thermoplastics
(e.g.: TECAFORM, TECAPET, TECAPEEK)
- Fibre reinforced thermoplastics
(e.g.: TECAPEEK PVX, TECAMID 6 GF 30, TECAMID 66 CF20, TECADUR PBT GF 30)
- Fabric reinforced thermoplastics
(e.g.: TECATEC PEEK CW 50)
- PTFE modified thermoplastics
(e.g.: TECAPET TF, TECAPEEK TF10 blue)



Differences between plastics and metal

Compared to metals, plastics have a wide range of benefits to offer, although a number of restrictions must also be borne in mind. Basically, the use of plastics is possible in those areas where in particular a favourable ratio between weight and strength is required.

Plastic offers a solution for applications calling for two to three of the following characteristic benefits. However, in order to be able to utilise the benefits of plastics when substituting other materials, the component may also have to be redesigned.

⊕ **Benefits over metal**

- Low density
- Good noise and vibration damping
- Electrical insulation or adjustable conductivity
- Good chemical resistance
- Scope for free design
- Permeability to electromagnetic waves
- Very good corrosion resistance
- Thermal insulation
- Application-specific modification possible

⊖ **Limitations compared to metal**

- Relatively low thermal resistance
- Greater thermal expansion
- Lower mechanical characteristics
- Poorer creep resistance

The above mentioned advantages and disadvantages of plastics compared to metals are to be observed especially in processes involving technical machining.

⚠ **To be noted:**

- Good thermal insulation
- Lower thermal conductivity
- Heat is not or only partly dissipated via the machined component, as in metal processing
- Higher thermal expansion than metals
- Good fixation and support of plastics in processing



⚠ **Possible consequences, if not observed**

- Too much heat input in the component can lead to high stress levels and thus to warping or fracture.
- Excessive heat input causes expansion of the plastic. The required tolerances of machined parts can thus not be maintained
- Inadequate fixation may lead to deformation during machining

💡 **Recommendations**

- Good heat dissipation - best via the material chips - as well as adequate fixation

This approach needs to be adapted depending on the plastic, in order to establish the optimum cutting tools and parameters for all thermoplastic materials. Only in this way can optimum components be made. Detailed information on the machining of plastic materials is available on the following pages.

What role does extrusion technology play in machining?

Manufacturing processes, especially the extrusion of semi-finished goods, have an impact on the properties and the workability of a material.

Plastic semi-finished goods made of PTFE or polyimides can be manufactured by compression and sintering. An important processing technology for other thermoplastics is the extrusion process. In this shaping process, materials are melted and compressed in a cylinder via a screw conveyor and homogenised. Using the pressure arising in the cylinder – and the appropriate tooling – semi-finished goods are delivered in the form of sheets, round rods and tubes and calibrated via a cooling system.

Impact

- Internal tension develops
- Fibres take up a specific orientation (if available)

Ensinger offers a broad product portfolio of semi-finished engineering plastics and high-temperature plastics. Standard plastic materials round off the portfolio. All these materials are manufactured so they may be processed optimally by machining.

Internal tension

The resulting pressure in the extrusion process produces a shear movement and flow of the plastic molten mass. The semi-finished goods discharged by the tool slowly cool from the marginal layer to the centre. The poor thermal conductivity of plastics results in different cooling rates. Whereas the margins have already solidified, the centre still contains plastic in the liquid state or fused plastic. Plastics are subject to a typical shrinkage pattern for that material. During the cooling phase, the plastic centre is hindered from contracting by the rigid boundary layer.

Impact of the technological process

- Internal stresses (in the centre) are due to the technological process
- Semi-finished products are difficult to machine
 - ↳ High risk of tearing and fractures

Possible solutions

- Material-specific annealing to minimise stresses (→ p. 19)

Tools and machines for processing plastics

For the machine processing of plastics/semi-finished goods, normal commercially available machines from the wood and metal working industries can be used with tools made of high-speed steel (HSS).

In principle tools with cutting edge angles like those used with aluminium are suitable. But we recommend the use of special tools for plastic with sharper wedge angle.

Hardened steel tools should not be used for processing reinforced plastics, due to the low holding times and the long processing times. In this case, the use of tungsten carbide, ceramic or diamond-tipped tools is advisable. Similarly, circular saws fitted with carbide tipped saw blades are ideal for cutting plastics.

Recommendations

- Use tools which are specific for plastics
- Have a suitable cutting geometry
- Very well sharpened tools

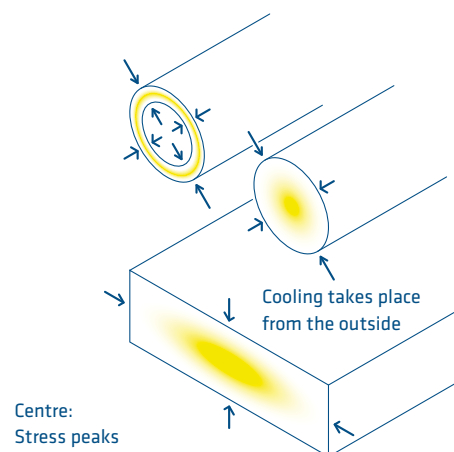

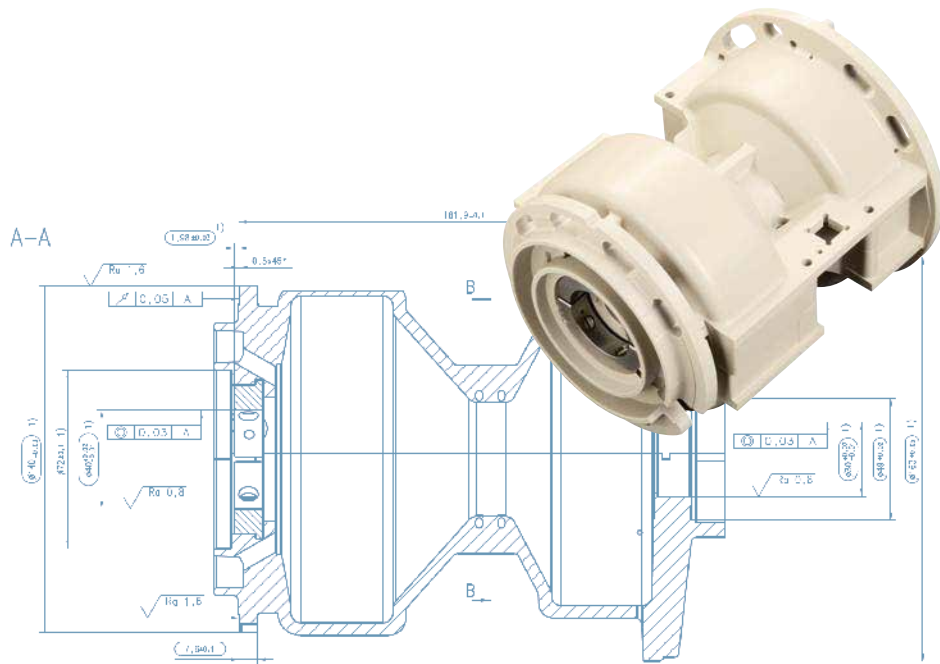

Machining

Machining (defined according to DIN 8580) is the fastest and most economic way to produce precise components, especially in small volumes. Very narrow tolerances can be achieved using machining procedures.

Ensinger itself has decades of experience in the field of machine processing of engineering and high-temperature plastics. This know-how allows us to produce highly precise components made of different plastics using in-house machining. Furthermore, we shall be pleased to support you with processing information about the machining and further processing of our semi-finished goods or pre-produced products using injection moulding or direct forming processes.

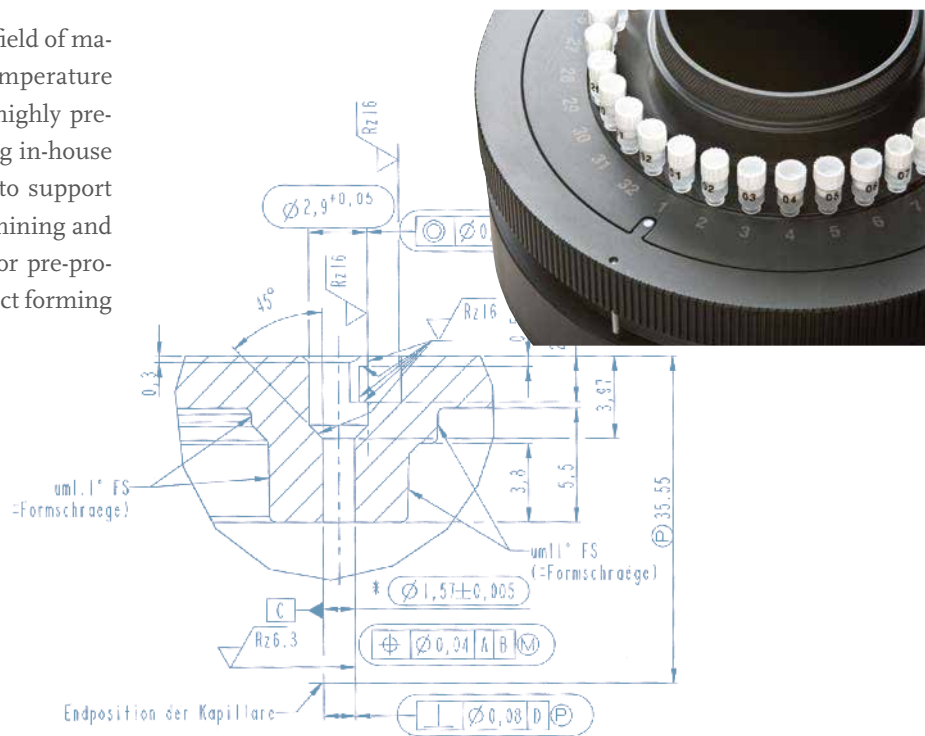

Cutting



What sawing processes are best suited to cut plastic parts?

Plastics can be cut using a band saw or a circular saw. The choice depends on the shape of the stock shape. Generally speaking, heat generated by the tooling when processing plastics and hence damage to the material is the greatest danger. For this reason, the right saw blade must be used for every shape and material.

Band saws

- Most suitable for cutting to size round rods and tubes
- It is recommended that support wedges are used
- Sharp and sufficiently set saw blades should be used
 - ↳ Good chip removal
 - ↳ Avoidance of high friction between the saw blade and material as well as excessive thermal build-up
 - ↳ Avoids saw blade blocking

⊕ Advantage:

- Heat generated by sawing is well dissipated thanks to the long saw blade
- Band saws allow versatile application for straight, continuous or irregular cuts
- Produces a good cutting edge quality

Circular saws

- Mainly suited for cutting plates to size with straight cutting edges
- Table circular saws can be used with the right power drive for straight cuts of plates with thicknesses of up to 100 mm
- Saw blades should be made of hardened metal
- Use a sufficiently high enough feed rate and adequate offset
 - ↳ Leads to good chip deflection
 - ↳ Avoids sticking of the saw blade
 - ↳ Avoids overheating of the plastic in the saw cut
 - ↳ Leads to good cutting edge quality

💡 Recommendations

- Use a corresponding tensioning device:
 - ↳ Avoidance of vibrations and unclean cutting edges which can result from this, or even lead to breakage
- Warm cutting of very hard and fibre-reinforced materials (pre-heat to 80 – 120 °C)
- Tungsten carbide saw blades wear well and provide an optimum surface finish

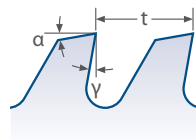

- α Clearance angle [°]
- γ Rake angle [°]
- t Pitch [mm]

Key facts at a glance

Ensure that set, sharp saw blades are used when sawing plastics.

How are plastics best processed on a lathe? (turning)

Plastics can be processed on commercially available lathes. For optimal results, however, specific plastic cutters should be used.

Cutting tools

- Use tools with small cutting radii
- Broad-nosed finishing cutting edge for high quality finish requirements
- Knifelike cutting geometries for machining flexible workpieces
- Use favourable geometries for fixing
- Special chisel geometry for parting off
- Cut circumferences and polished surfaces
- ⊕ **Advantage:**
 - Optimal, groove-less surface
 - Reduces the build-up of material on the application

💡 Recommendations

- Select a high cutting speed
- Use a cutting depth of at least 0.5 mm
- Compressed air is well suited for cooling
- Use of a lunette due to reduced rigidity of plastics
 - ↳ Stabilise the component
 - ↳ Avoidance of deformation
- ⊕ **Advantage:**
 - Good cooling of the material
 - Overcomes flow chipping which can arise with some plastics. Prevents jamming and rotating with the lathe part of the blade

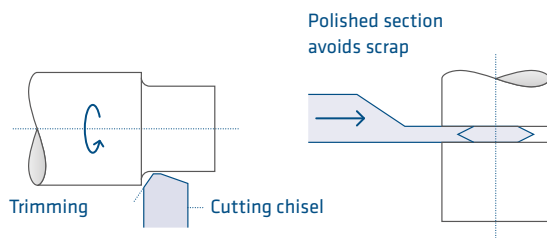

Milling recommendations

Plastics can be milled using customary machining centres. This should be done using tools with adequate chip space in order to guarantee reliable discharge of chips and prevent overheating.

Tools

- Suitable for thermoplastics
 - ↳ Slot milling cutter
 - ↳ Face milling cutter
 - ↳ Cylindrical milling cutter
 - ↳ Single cutter tools
 - ↳ Fly cutter
- Single cutter tools
 - ⊕ **Advantage:**
 - ↳ Optimal average high cutting performance
 - ↳ High surface quality with good chip removal at the same time

💡 Recommendations

- High cutting speeds and medium feed rates
- Ensure good attachment:
 - ↳ Rapid method for the table and a high spindle speed coupled with correct fixture alignment lead to higher quality machined finish
- Thin work-pieces can be secured using a suction fixture or dual-sided adhesive tape on the router table
- For flat surfaces, end milling is more economical than peripheral milling
- During peripheral milling, tools should not have more than two cutting edges in order to minimize vibrations caused by a high number of cutting edges, and chip spaces should be adequately dimensioned

How better milling surfaces can be achieved

- For surface milling, choose a low chip angle
- Optimal cutting performance and surface qualities result from single cutter tools
- Down milling should be used in preference to conventional milling

Drilling engineering plastics

When drilling plastic components, select a method suitable for plastic materials in order to avoid defects. Otherwise, there is a danger of breaking, tearing, overheating or dimensional deviations of the drill holes.

When drilling, particular attention must be paid to the insulating characteristics of plastic. These can cause plastics (especially semi-crystalline ones) to quickly build up heat during the drilling process, particularly if the drilling depth is more than twice the diameter. This can lead to “smearing” of the drill and an inner expansion arising in the component, which can lead to compressive stress in the part (especially when drilling into the centre of round rod sections). The stress levels can be high enough to cause a high level of warping, dimensional inaccuracy, or even cracks, fractures and bursting open of the finished component or blank. Appropriate processing for the material will prevent this.

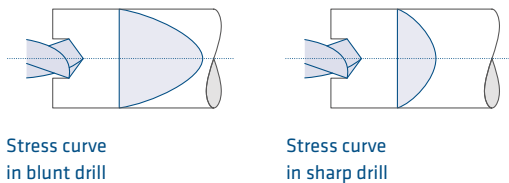

Tools

- Well-sharpened commercially available HSS drills are normally sufficient
- Use drills with a narrow bridge (synchronised drilling):
 - ↳ Reduced friction and avoidance of a build-up of heat

Recommendations

- Use a coolant
- Frequent withdrawal of the drill:
 - ↳ Chip removal
 - ↳ Additional cooling
- Avoid the use of a manual feed:
 - ↳ Ensures that the drill does not become caught
 - ↳ Prevents cracking

Recommendations for drilling small diameter holes (< 25 mm)

- Use of high-speed steel drills (HSS drills)
- Use a spiral drill
- Twist angle of 12 – 25°:
 - ↳ Very smooth spiral grooves
 - ↳ Favours chip deflection
- Frequent removal of the drill (intermittent drilling)
 - ↳ Better removal of the chips and avoidance of thermal build-up
- In the case of thin-walled components it is recommended to use:
 - ↳ High cutting rates
 - ↳ If possible, select a neutral (0°) chipping angle in order to avoid drill catching in the component and thus tearing of the drill and/or lifting of the work-piece by the drill

Recommendations for drilling large diameter holes (> 25 mm)

- Carry out a trial drilling with large drill holes
- Select a pre-drilling diameter which is no larger than 25 mm
- Carry out finishing subsequently with an inner cutting chisel
- Introduce drilling into long rod sections only from one side
 - ↳ In the case of drilling attempts which meet in the middle (bilateral drilling), unfavourable tension characteristics may arise, or even tearing
- In extreme cases/in the case of reinforced materials, it may be advisable to carry out the drilling on a pre-warmed component at approx. 120°C (heating time approx. 1 hour per 10 mm cross-section)
 - ↳ To ensure dimensional accuracy, finish machining then takes place after the blank has cooled down completely

Key facts at a glance

**Ensure that the drill is sharp.
Furthermore, do not exert pressure which is too high.**

Cutting threads

Threads are best introduced into engineering plastics using chasing tools for male threads or milling for female threads.

Tools

- Use of a chasing tools
- Two-dentate chaser avoids burr formation
- Dies are not recommended. In the case of a return, re-cutting is possible

🔗 Recommendations

- Taps often have to be provided with an allowance (dependent upon material and diameter, approx. value: 0.1mm)
- Do not select a pre-setting which is too high, in order to avoid squashing of the thread

Planing / plane milling

Planing and plane milling are chip production methods with geometrically determined cutting for the manufacture of certain cuts to produce equal surfaces, grooves or profiles (using shaping milling).

Both procedures differ only in that with planing a straight line of material removal is made across the surface using a planing machine cutting tool. In the case of plane milling, on the other hand, the surface is processed using a milling head. Both processes are well-suited to produce even and/or equalised surfaces on semi-finished goods. The main difference is that optically different surfaces arise (surface structure, gloss).

Planing and plane milling at Ensinger

- Ensinger can offer both planed as well as plane milled semi-finished goods via the cutting to size service
- Sheets > 600 mm can only be processed using the plane milling process
- Sheets < 600 mm can be processed using both processes
- Small cuts are processed using planing



Milled surface



Planed surface

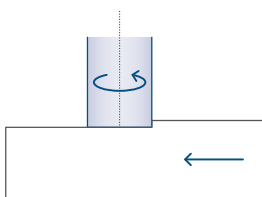

Plane milling

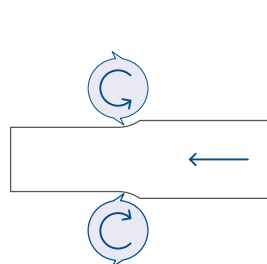

Planing

Grinding

In grinding, the overall effect of cutting, work-piece, delivery and feed movements results in a continuous chip removal from the surface being processed. The grinding result is influenced by

- the grinding machine
- the tool being used
- the grinding medium
- the working parameters of the grinding process
- the material to be processed
- the roundness/straightness of the semi-finished goods

Particularly decisive working parameters are:

- cutting speed
- forward rate of advance
- delivery
- cross-sectional advance rate

Optimally adjusted machinery and the right choice of parameters for the corresponding material ensure that very good surface quality with slight roughness diameter tolerances up to h9, roundness and straightness can be achieved.

Grinding at Ensinger

We are able to provide ground round rods via our cutting service. Thanks to a high surface quality and narrow tolerances, ground round rods are easily further processed and are suitable for continuous production processes.

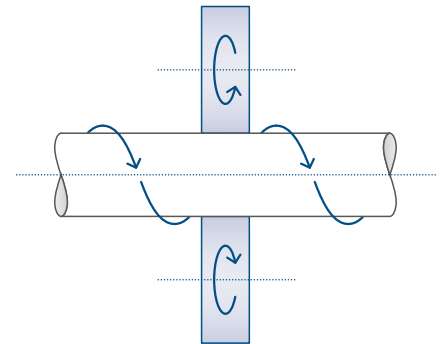

Surface quality, reworking and de-burring

To obtain a good surface quality, the following guidelines should be followed:

Tools

- Tools suitable for plastics must be used
- Tools must always be well sharpened and smooth (sharpened cutting edge). Blunt cutting edges can lead to increased heat generation, resulting in distortion and thermal expansion
- Tools should be adequately spaced to ensure that only the cutting edge comes into contact with the plastic

Processing machine

- Flawless, high-quality finished surfaces can only be achieved with low-vibration machine running

Material

- Use low-tension annealed material (semi-finished goods from Ensinger are generally low-tension annealed)
- Note the properties of the plastic (thermal expansion, low strength, poor heat conduction...)
- Due to the minimal rigidity of the material, the work-piece must be adequately supported and lie as flat as possible on the supporting surface in order to avoid deflection and out-of-tolerance results

Cooling

- Use coolants for processes involving the generation of high levels of heat (such as drilling)
- Use suitable coolants

Recommendations

- Tension pressures must not be too high, as otherwise deformations and impression marks can result on the work-piece
- Select suitable parameters for the machining process (→ p. 15)
- Keep feed rate to a moderate level
- Select a high cutting speed
- Good removal of chips must be guaranteed in order to prevent tool congestion
- Ensure that chip removal is equal on all sides in order to prevent warping

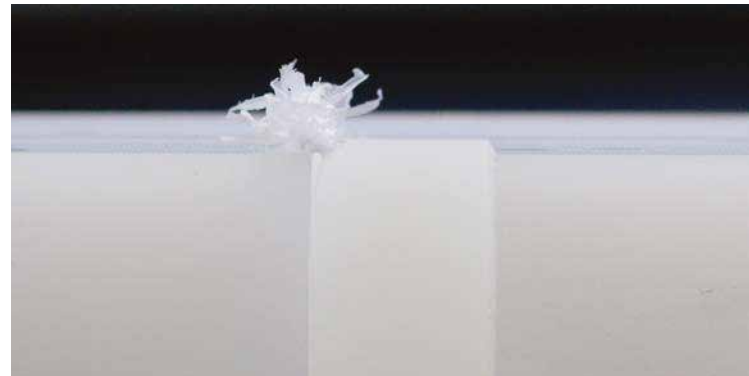

De-burring

After milling, grinding, drilling, turning or engraving, a small piece of the material to be processed remains on the work-piece or its edges. This flash negatively influences the quality of the surface of the component. In plastics processing, burr formation depends in particular on a number of different parameters.

Tooling

- Select tooling which is specific for a particular material
- Condition of the tool:
 - ↳ Blunt tools cause a much higher level of heat development and burr formation

Material

- Poor thermally conducting plastics:
 - ↳ Local increased temperatures, reduction of rigidity and hardness
 - ↳ Melting burrs/flash
- There is a tendency for soft, tough plastics (e.g.: PE, PTFE) to show more burr formation; hard, stiffer materials (e.g.: PEEK, PPS, fibre-reinforced material) less

Processing parameters

- Material advancement rate
- Cutting speed:
 - ↳ Higher advancement rates and cutting speeds lead to higher temperatures
 - ↳ Greater burr formation
- Ensure adequate cooling

For the reasons mentioned, it is important to select a suitable tool for each material and to establish the right parameters, in order to achieve the best possible and flash-free surfaces and edges.

Typical de-burring methods for engineering plastics

Manual de-burring

- Most common method of de-burring
- Flexible, but most work intensive
- At the same time, visual control of the component can be performed

Jet de-burring

- Jet of abrasive material at high pressure used on the surface of the component; common blasting methods: sand, glass balls, soda, dry-ice and nutshell blasting
- Also, represents surface treatment methods
 - ↳ Smoothing
 - ↳ Roughening
 - ↳ Removal of contamination

Cryogenic de-burring

- Removal of burrs at temperatures around $-195\text{ }^{\circ}\text{C}$ via the use of a jet or drum tumbling of the components
- Frequent coolants: liquid oxygen, liquid carbon dioxide, dry-ice
- Low temperatures lead to brittleness and hardness of the materials

Flame de-burring

- De-burring using an open flame
- Danger: damage may be caused to the component due to excessive heat development

Hot-air de-burring

- The flash melts under the influence of heat
- Very safe and well controllable process
- Avoidance of damage or warping of the component when using process management suitable for the material

Infrared de-burring

- Process is comparable to hot-air de-burring, instead of hot air, an infrared heat source is used for heating

Rumbling / Trovalising

- Treating the parts together with abrasives in rotating / vibrating

Machining guidelines

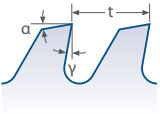
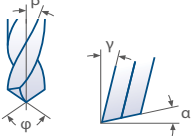
	Sawing				Drilling				
	 α Clearance angle [°] γ Rake angle [°] t Pitch [mm]				 α Clearance angle [°] β Twist angle [°] γ Rake angle [°] φ Point angle [°] V Cutting speed [rpm] S Feed rate [mm/r]				
	Circular saw	Band saw			Number of teeth	Twist angle	Rake angle	Cutting speed	Feed rate
	Rotation speed [rpm]	Pitch	Cutting speed [m/min]	Pitch					
TECAFINE PE/PP	2800 – 3000	31 – 38	130 – 180	11 – 15	Z2	25	90	50 – 150	0.1 – 0.3
TECAFINE PMP	2800 – 3000	31 – 38	130 – 180	11 – 15	Z2	25	90	50 – 150	0.1 – 0.3
TECARAN ABS	2600	31 – 38	130 – 180	11 – 15	Z2	25	90	50 – 200	0.2 – 0.3
TECANYL	2800 – 3000	31 – 38	130 – 180	11 – 15	Z2	25	90	50 – 100	0.2 – 0.3
TECAFORM AD/AH	2800 – 3000	31 – 38	130 – 180	11 – 15	Z2	25	90	50 – 150	0.1 – 0.3
TECAMID, TECARIM, TECAST	2000 – 2600	31 – 38	130 – 180	11 – 15	Z2	25	90	50 – 150	0.1 – 0.3
TECADUR/TECAPET	2200 – 2600	31 – 38	130 – 180	11 – 15	Z2	25	90	50 – 100	0.2 – 0.3
TECANAT	2400	31 – 38	130 – 180	11 – 15	Z2	25	90	50 – 100	0.2 – 0.3
TECAFLON PTFE/PVDF	2800 – 3000	20 – 24	130 – 180	11 – 15	Z2	25	90	150 – 200	0.1 – 0.3
TECAPEI	3000	20 – 24	130 – 180	11 – 15	Z2	25	90	20 – 80	0.1 – 0.3
TECASON S, P, E	3000	20 – 24	130 – 180	11 – 15	Z2	25	90	20 – 80	0.1 – 0.3
TECATRON	3000	20 – 24	130 – 180	11 – 15	Z2	25	90	50 – 200	0.1 – 0.3
TECAPEEK	3000	20 – 24	130 – 180	11 – 15	Z2	25	90	50 – 200	0.1 – 0.3
TECATOR	3000	20 – 24	130 – 180	11 – 15	Z2	25	90	80 – 100	0.02 – 0.1
TECASINT	3000	20 – 24	130 – 180	11 – 15	Z2	25	120	80 – 100	0.02 – 0.1
Reinforced/filled TECA products*	2400 – 2800	20 – 24	110 – 150	11 – 15	Z2	25	100	80 – 100	0.1 – 0.3

* Reinforcing agents/fillers:
Glass fibres, glass beads, carbon fibres, graphite, mica, talcum, etc.

Heat before sawing:
from Ø 60 mm TECAPEEK GF/PVX, TECATRON GF/PVX
from Ø 80 mm TECAMID 66 GF, TECAPET, TECADUR PBT GF
from Ø 100 mm TECAMID 6 GF, 66, 66 MH

Heat before drilling in the centre:
from Ø 60 mm TECAPEEK GF/PVX, TECATRON GF/PVX
from Ø 80 mm TECAMID 66 MH, 66 GF, TECAPET, TECADUR PBT GF
from Ø 100 mm TECAMID 6 GF, 66, TECAM 6 MO, TECANYL GF

Recommendation
Diameter of circular saw blade = 450 – 480 mm
Circular saw tooth type = Alternating teeth
Circular saw blades from hard metal. For reinforced materials a diamond-studded sawing blade is recommended for better tool life.
Band saw blades from hard metal, well set.

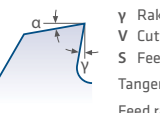
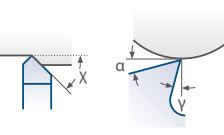
	Milling			Turning				
	 α Clearance angle [°] γ Rake angle [°] V Cutting speed [rpm] S Feed rate [mm/r] Tangential feed Feed rate can be up to 0,5 mm / tooth			 α Clearance angle [°] γ Rake angle [°] χ Side angle [°] V Cutting speed [rpm] S Feed rate [mm/r] The nose radius r must be at least 0,5 mm				
	Number of teeth	Cutting speed	Feed rate	Clearance angle	Rake angle	Side angle	Cutting speed	Feed rate
TECAFINE PE, PP	Z2 – Z4	250 – 500	0.1 – 0.45	6 – 10	0 – 5	45 – 60	250 – 500	0.1 – 0.5
TECAFINE PMP	Z2 – Z4	250 – 500	0.1 – 0.45	6 – 10	0 – 5	45 – 60	250 – 500	0.1 – 0.5
TECARAN ABS	Z2 – Z4	300 – 500	0.1 – 0.45	5 – 15	25 – 30	15	200 – 500	0.2 – 0.5
TECANYL	Z2 – Z4	300	0.15 – 0.5	5 – 10	6 – 8	45 – 60	300	0.1 – 0.5
TECAFORM AD, AH	Z2 – Z4	300	0.15 – 0.5	6 – 8	0 – 5	45 – 60	300 – 600	0.1 – 0.4
TECAMID, TECARIM, TECAST	Z2 – Z4	250 – 500	0.1 – 0.45	6 – 10	0 – 5	45 – 60	250 – 500	0.1 – 0.5
TECADUR/TECAPET	Z2 – Z4	300	0.15 – 0.5	5 – 10	0 – 5	45 – 60	300 – 400	0.2 – 0.4
TECANAT	Z2 – Z4	300	0.15 – 0.4	5 – 10	6 – 8	45 – 60	300	0.1 – 0.5
TECAFLON PTFE, PVDF	Z2 – Z4	150 – 500	0.1 – 0.45	5 – 10	5 – 8	10	150 – 500	0.1 – 0.3
TECAPEI	Z2 – Z4	250 – 500	0.1 – 0.45	10	0	45 – 60	350 – 400	0.1 – 0.3
TECASON S, P, E	Z2 – Z4	250 – 500	0.1 – 0.45	6	0	45 – 60	350 – 400	0.1 – 0.3
TECATRON	Z2 – Z4	250 – 500	0.1 – 0.45	6	0 – 5	45 – 60	250 – 500	0.1 – 0.5
TECAPEEK	Z2 – Z4	250 – 500	0.1 – 0.45	6 – 8	0 – 5	45 – 60	250 – 500	0.1 – 0.5
TECATOR	Z2 – Z4	60 – 100	0.05 – 0.35	6 – 8	0 – 5	7 – 10	100 – 120	0.05 – 0.08
TECASINT	Z2 – Z4	90 – 100	0.05 – 0.35	2 – 5	0 – 5	7 – 10	100 – 120	0.05 – 0.08
Reinforced/filled TECA products*	Z2 – Z4	80 – 150	0.05 – 0.4	6 – 8	2 – 8	45 – 60	80 – 150	0.1 – 0.5

* Reinforcing agents/fillers:
Glass fibres, glass beads, carbon fibres, graphite, mica, talcum, etc.

● Preheat material to 120 °C
● Caution when using coolants: susceptible to stress cracking

Interview: with Hufschmied Zerspanungssysteme

What is the business of the Hufschmied Company?

Hufschmied is specialised in the development and manufacture of “material-optimised machining tools” for the field of plastics and composites. Our tooling is manufactured in-house using CNC 6-axis grinding centres. In this way, short throughput times are possible from the enquiry to the delivery. High-grade fully hardened metals and ceramics serve as the basic materials, which are coated according to the requirements of the customer.

What is your experience in the field of machining plastics in general?

Hufschmied has been present in the market for more than 25 years. Very early on we have concentrated on the machining of plastics, as it was evident that this is where high growth was to be expected. Plastics continue to develop rapidly and new high-tech materials are added to the market every day. As we work with different material manufacturers and universities, we always have the possibility to come into contact at a very early stage with novel materials. These are then machined in our own laboratory. In this way, we can support our customers at an early stage with appropriate tools and processes.

How do you react to the new challenges involved with the new materials?

To date, we have been able to machine all plastics, even if sometimes several optimization loops were needed for the tooling. Plastics are becoming more diverse, so that we need to adjust the tool geometries accordingly. A material data sheet is helpful, especially with “filled” materials. As we do not manufacture the plastics ourselves and are not able to analyze them in every detail, we have to be able to rely on this information. If these then fit the general conditions such as machine set-up, tools and parameters, we are able to achieve the desired result fairly quickly. All our trial results are brought together in a knowledge database and analyzed. This database is a cornerstone of our processing knowledge and supports us in the tool and process development.

Process development

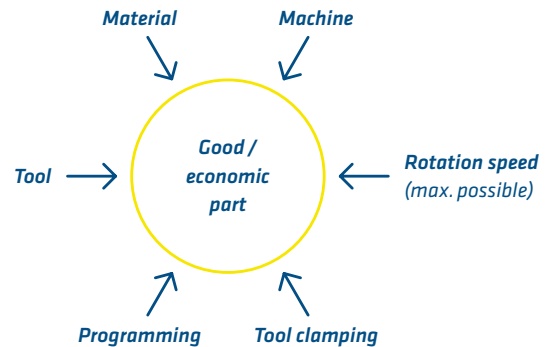

What philosophy do you follow in plastics processing?

We always design our plastic tooling for dry machining. It is relatively seldom that we are able to machine under “wet” conditions: The application or the purpose of the component often does not allow this.

Additives are included in all coolants and can adverse reactions during the machining of plastics and additives. Our tools are designed for machining at high feed rates. High feed rates are used to ensure that there is no temperature dissipated into the component, but into the chips. These parameter adjustments are often made on site, because the customer does not want to risk “cutting corners” due to a lack of experience.

What do you see as the main problems in the plastics processing market?

In my opinion, the customer is still focused too much on the metalworking industry. This often results in problems with “smeared” effects, warpage, cracking or burr formation. In particular, the burr formation is a concern for our customers, as this makes a lot of reworking time necessary. We often then change only a few essential small things in the machining program to avoid rework. Many customers want a universal tool with which a majority of components and materials can be processed. Unfortunately, this is rarely possible, since different materials also require respective tool geometries. The tool has to be adapted especially for high-end applications, to match the material and the part. Only in this way is appropriate processing possible which is reliable and cost-effective.

Which plastics in your opinion are from a technical machining point of view particularly critical or non-critical in their workability?

Carbon or glass-fibre filled plastics are definitely challenging. Currently, more and more plastics with ceramic fillers are being used. This can make life difficult for a tool! But if we know what is contained in the material, we can respond accordingly. Materials such as PE, POM, PC, and PTFE can be handled without any major problems arising with the right tools, the right parameters and a good machine. But the framework of conditions must also agree in detail.

Do you have a specific recommendation how to determine the optimum machining method for plastics?

I need to know definitely how the machine works. How it copes with small radii or rapid feed rates? If this has all been determined, I can refer to the drawings, go to the available speeds, feed rates and work-piece clamping on the selected tool. As soon as the tools are defined, the programs can be adapted. Basic values can be found on our homepage www.hufschmied.net. The counter rotation is always a big issue in this respect. Many people program the machine – as used in the processing of steel – in counter rotation and then have major problems with burrs and a poor surface finish.

Are there industries where the special needs in plastics processing have to be particularly taken into account?

Every industry has its own terms of reference to which we have to adapt ourselves. For example, the medical device industry. Dry machining is mostly carried out here. Very small parts also often have to be produced. These usually require special tools. We often work with micro-drills and extreme lengths in cutting. On smooth surfaces a minimum depth of roughness has to be produced. A small advantage is that highly accurately working machines are used.

What properties do you take as a benchmark to determine the machining ability of plastics?

In order to limit the machinability to some extent, we mostly need the following details:

- Material identification which is as accurate as possible
- Is the material filled or further modified?
- Does the material come from a rod or a sheet?
- What is the final product to look like?
- What machine is available?
- How is the work-piece clamped?

Based on these statements, the machining ability can possibly be determined. We shall be pleased to also carry out tests on our own machinery. In this respect, a test protocol is prepared with parameters, photos and a demonstration video.

What parameters can be used to optimise the machining processes?

As already mentioned, the following parameters are important for good machining:

- Turning speed
- Feed per tooth
- The clamping of the work-piece and tool
- Synchronised and counter rotation
- Cooling
- Program structure

The most important parameter is nevertheless the machining tool.

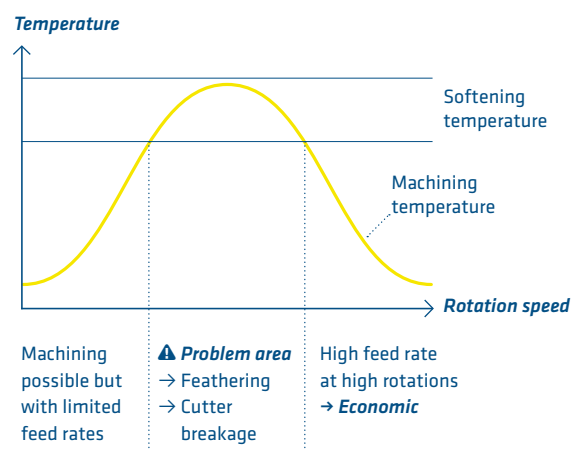

Ralph Hufschmied, Nabil Khairallah
(Hufschmied Zerspanungssysteme),
interview by Holger Werz (Ensinger GmbH)

Cooling and cooling lubricants

Currently there is a trend towards using dry machining with engineering plastics. As there is now sufficient experience available in this area, it is frequently possible to do without the use of cooling lubricants. Exceptions for thermoplastic machining processes are:

- Deep drill holes
- Thread cutting
- Sawing reinforced materials

However, it is possible to use a cooled cutting surface to improve both the surface quality and tolerances of the machined plastic parts, and also to allow faster feed rates and consequently reduced running times.

Machining with coolants

If cooling is required, it is recommended to cool

- Via the chippings
- Using compressed air
 - ↳ Advantage: Cooling and removal of the chips at the same time from the working area
- Use of water soluble coolants
- Commercially available drilling emulsions and cutting oils can also be used
 - ↳ Spray mist and compressed air are very effective methods

Machining amorphous plastics

- Avoid using coolants:
 - ↳ Materials liable to develop tension tearing
- If cooling is imperative:
 - ↳ Parts should be rinsed in pure water or isopropanol right after machining
 - ↳ Use suitable coolants
- Pure water
- Compressed air
- Special lubricants: Information about suitable lubricants is available from your lubricant supplier

⊕ Advantages of dry machining

- No media residues on the components
 - ↳ Advantageous for components used in medical device technology or in the food industry (no migration)
 - ↳ Influence of cooling lubricants on the material can be excluded. (Swelling, change of dimensions, tension tearing, ...)
 - ↳ No interaction with the material
 - ↳ False assessment / treatment from machinist is excluded

ⓘ Note

- especially with dry machining, cooling is essential to achieve good dissipation of heat!

Key facts at a glance

Generally speaking, dry processing is to be recommended with heat dissipation via the machining chips.



Annealing

Annealing process

The annealing process involves thermal treatment of semi-finished goods, moulded or finished parts. The products are slowly and evenly warmed to a material specific, defined temperature level. There then follows a holding period which depends on the material and its thickness, in order to thoroughly heat through the moulded part. Subsequently the material has to be slowly and evenly cooled back down to room temperature.

Reducing tension by annealing

- Residual tensions, which have arisen during manufacture or processing, can be extensively and almost completely reduced by annealing
- Increase in the crystallinity of materials
 - ↳ Optimize mechanical material values
- Formation of an even crystalline structure in materials
- Partly improve the chemical resistance
- Reduction of warping tendency and dimensional changes (during or after processing)
- Sustainable improvement in dimensional stability

Semi-finished goods at Ensinger are subjected to an annealing step after production. In this way, it can be ensured that the material that you receive will remain dimensionally stable during and following processing and can also be better processed by machining.

Intermediate annealing

It may also be wise to subject critical components to an intermediate annealing step when processing. This applies especially,

- If narrow tolerances are required
- If components with a strong tendency to warp due to the required shape need to be produced (asymmetric, narrowed cross-sections, pockets and grooves)
- In the case of fibre-reinforced/filled materials (fibre orientation can enhance warping)
 - ↳ Processing can lead to further, enhanced tension being introduced into the component.
- Use of blunt or unsuitable tools:
 - ↳ Initiators of tension
- Excessive heat input into the component – produced by inappropriate speeds and feed rates
- High stock removal volumes - primarily as a result of one-sided machining

Material	Polymer Abbreviation	Heating-up phase		Maintaining phase*	Cooling down phase
TECASINT	PI	2 h to 160 °C	6 h to 280 °C	2 h at 160 °C / 10 h at 280 °C	at 20 °C / h to 40 °C
TECAPEEK	PEEK	3 h to 120 °C	4 h to 220 °C	1,5 h per cm wall thickness	at 20 °C / h to 40 °C
TECATRON	PPS	3 h to 120 °C	4 h to 220 °C	1,5 h per cm wall thickness	at 20 °C / h to 40 °C
TECASON E	PES	3 h to 100 °C	4 h to 200 °C	1 h per cm wall thickness	at 20 °C / h to 40 °C
TECASON P	PPSU	3 h to 100 °C	4 h to 200 °C	1 h per cm wall thickness	at 20 °C / h to 40 °C
TECASON S	PSU	3 h to 100 °C	3 h to 165 °C	1 h per cm wall thickness	at 20 °C / h to 40 °C
TECAFLON PVDF	PVDF	3 h to 90 °C	3 h to 150 °C	1 h per cm wall thickness	at 20 °C / h to 40 °C
TECANAT	PC	3 h to 80 °C	3 h to 130 °C	1 h per cm wall thickness	at 20 °C / h to 40 °C
TECAPET	PET	3 h to 100 °C	4 h to 180 °C	1 h per cm wall thickness	at 20 °C / h to 40 °C
TECADUR PBT GF30	PBT	3 h to 100 °C	4 h to 180 °C	1 h per cm wall thickness	at 20 °C / h to 40 °C
TECAMID 6	PA6	3 h to 90 °C	3 h to 160 °C	1 h per cm wall thickness	at 20 °C / h to 40 °C
TECAMID 66	PA66	3 h to 100 °C	4 h to 180 °C	1 h per cm wall thickness	at 20 °C / h to 40 °C
TECAFORM AH	POM-C	3 h to 90 °C	3 h to 155 °C	1 h per cm wall thickness	at 20 °C / h to 40 °C
TECAFORM AD	POM-H	3 h to 90 °C	3 h to 160 °C	1 h per cm wall thickness	at 20 °C / h to 40 °C

* At maximum temperature, unless otherwise specified.

An intermediate annealing step can help to reduce these tensions and alleviate the risk of warping. In this respect, care should be taken that the required dimensions and tolerances are observed:

- Components prior to intermediate annealing should first be dimensionally pre-worked with an approximate safety margin (roughening)
 - ↳ Annealing can lead to a certain shrinkage of the components
- Subsequently, the final dimensioning of the parts should be made
- Support the component well during the intermediate annealing step:
 - ↳ Avoidance of warping during annealing

Representative annealing cycle

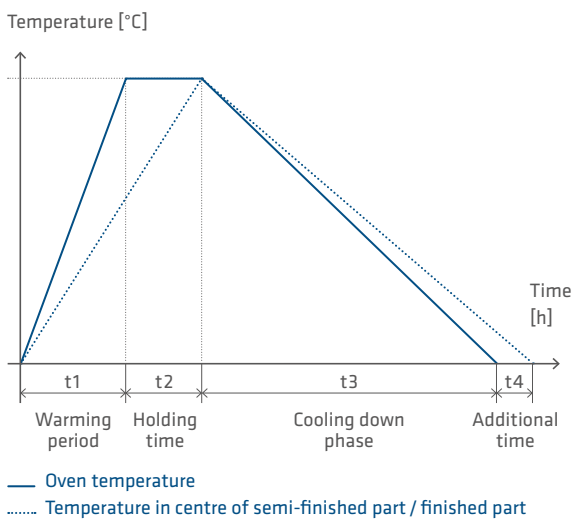

Morphological changes and post-shrinkage

The heat treatment of plastics always has direct effects on the materials and their processing:

- Annealing
- Machining (frictional heat)
- Use (service temperature, hot steam sterilisation)

Partially crystalline plastics

- Annealing process leads to equalisation of material properties
 - ↳ Increase in the crystallinity
 - ↳ Optimisation of mechanical properties
 - ↳ Improved dimensional stability
 - ↳ Better chemical resistance
- Machining can lead to local overheating through frictional heat. Consequence:
 - ↳ Microstructural changes
 - ↳ Post-shrinkage
- Particularly critical in this respect is TECAFORM
 - ↳ Improper machining can lead to severe deformation and/or warping of the component

Amorphous plastics

- Are less critical with regard to their post-shrinkage and warping

Exemplary warpage issue due to one-sided machining

1. Yellow = material to remove



2. Warpage after material has been removed one-sided

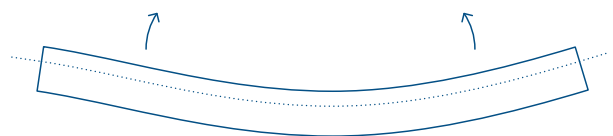

Key facts at a glance

Annealing/tempering leads to an optimum dimensional stability and lowers the tension level. In the case of amorphous materials, heat treatment also reduces the sensitivity to tension tearing.

Dimensional stability

Dimensional stability is to be considered a characteristic in every system in each process step – from the manufacture of semi-finished plastics to the final end use. There are various causes which can influence the dimensional stability of a component.

Moisture uptake:

- Plastics with lower moisture uptake are generally very much more dimensionally stable. Example: TECAFORM AH / AD, TECAPET, TECATRON, TECAPEEK
 - ↳ Can be achieved with narrow tolerances
- Plastics with high levels of moisture uptake show a marked influence on dimensional stability
Example: TECAMID, TECAST
 - ↳ Moisture uptake/release leads to swelling or shrinkage of the material
 - ↳ Conditioning is possibly recommended prior to processing

Tension relaxation

- Internal or “frozen in” tension acts only partly or has little effect on the dimensional stability of the finished part during processing at room temperature.
 - ↳ Dimensionally stable finished part
- During storage or in use, this “frozen in” tension can break down
 - ↳ Dimensional changes.
- Particularly critical: Use of components at higher temperatures:
 - ↳ Tension can be reduced suddenly.
 - ↳ Change of shape, warping or in the worst case tension tearing when using the component

Heat input

- All processes are critical in which heat develops in the material
 - ↳ Example: Annealing, machining, use at high temperatures, sterilisation
- Temperatures above the glass transition temperature have an effect on microstructural changes and thus post-shrinkage after renewed cooling down
 - ↳ Shrinkage and warping are particularly apparent in asymmetrical component geometries

- ↳ Partly crystalline thermoplastics exhibit high post-shrinkage (up to ~1.0–2.5%) and are critical with regard to warping

- ↳ Amorphous thermoplastics show only slight post-shrinkage characteristics (~0.3–0.7%) and are more dimensionally stable than partly crystalline thermoplastics

- In many cases, higher thermal expansion (compared to metal) must be taken into consideration

🔧 *Processing*

- Ensure good heat dissipation in order to avoid local temperature rise
- In the case of higher machining volumes it may be advisable to introduce an intermediate annealing step, in order to reduce the development of tension
- Plastics require greater production tolerances than metals
- Avoid higher tensional forces, in order to avoid distortion
- In the case of fibre-reinforced materials in particular, attention should be paid to the position of the component in the semi-finished goods (observe extrusion direction)
- When machining, a component optimised procedure should be chosen



Product groups and material characteristics

TECAFORM AH / AD, TECAPET, TECAPEEK

Semi-crystalline, unreinforced materials

TECAFORM AH / AD, TECAPET and TECAPEEK are very dimensionally stable materials with balanced mechanical properties. These materials are very easy to machine and basically tend to produce short chips. They can be machined with very high delivery and high feed rates.

Fundamentally, however, it is important to pay attention during processing to a low heat input as far as possible, as TECAFORM as well as TECAPET in particular have a high tendency to undergo post-shrinkage by up to ~2.5% - warping can arise thereby due to local overheating.

In the case of the materials mentioned above, very low surface roughness can be achieved with optimised machining parameters.

TECAST T, TECAMID 6, TECAMID 66 (Polyamides)

Unreinforced Polyamides

It should generally be remembered with polyamides: TECAST T, TECAMID 6 and TECAMID 66 are materials based on polyamides. Contrary to the previously mentioned materials, it should be remembered that polyamides have naturally very brittle characteristics – this may also be referred to in the context of a “freshly moulded” condition. Due to their chemical structure, the polyamides tend, however, to absorb moisture - this property gives the polyamides their very good balance between toughness and strength.

The moisture uptake via the surface leads to a virtually constant distribution of water content over the entire cross section with small semi-finished dimensions and components. In the case of larger dimensioned semi-finished goods (in particular for round rods / sheets of 100 mm diameter / wall thickness upwards) the moisture content decreases from the outside inwards.

In the most unfavourable case, the centre is of a brittle and hard character. Added to the internal tension produced by extrusion technology, machining can carry a certain risk of producing tension cracking.

In addition, it should be remembered that as a consequence moisture uptake can change the dimensions of the material. This “swelling” has to be allowed for in the processing and design of components made of polyamide. The moisture uptake (conditioning) of semi-finished goods plays an important part in the case of machining. Especially thin-walled components (up to ~10 mm) can absorb up to 3% moisture. As a rule of thumb:

→ A moisture uptake of 3% causes a dimensional change of about 0.5%!

Machining of TECAST T

→ Tends to produce short chips
→ Is therefore good to machine

Machining of TECAMID 6 and TECAMID 66

→ Form a flow of chips
→ More frequent removal of chips from the tool/work-piece can be necessary
→ Important in order to generate chips which break off when they are very short and to avoid breakdowns in the process:
→ Ideal machining parameters
→ Choice of suitable tools

Generally speaking, we recommend pre-heating to 80 – 120 °C with larger dimensioned work-pieces (e.g. round rods > 100 mm and sheets with a wall thickness > 80 mm) and machining close to the centre, in order to avoid tension cracking during processing.

Key facts at a glance

Amorphous plastics should be dry machined as far as possible. If the use of a cooling lubricant is absolutely necessary, the component should be subsequently cleaned immediately afterwards.

TECANAT, TECASON, TECAPEI

Amorphous thermoplastics

TECANAT, TECASON, TECAPEI are amorphous materials, which are very prone to develop tension cracking in contact with aggressive media, such as oils and fats. Also, cooling lubricants often contain media, which can trigger tension in the material. For this reason, avoid using cooling lubricants when machining these materials as far as possible or, for example, a water-based medium should be used.

Similarly, material specific machining parameters should be selected as far as possible.

- Do not use feed rates which are too high
- Avoid the use of higher pressures
- Avoid excessively high tensions
- Preferably select a higher rotational speed
- Use suitably sharp tools

ⓘ To be observed with construction designs

Construction designs should be adapted to match amorphous materials.

- Avoid shearing forces (constructive and in processing)
- Design edges/geometries according to the type of material (preferably choose inner edges which are slightly rounded-off)

The materials can be used to manufacture very dimensionally stable prefabricated parts with very narrow tolerances, taking suitable machining parameters into account.

TECA materials with PTFE

Materials containing a PTFE component (e.g. TECAFLON PTFE, TECAPEEK TF, TECAPEEK PVX, TECATRON PVX, TECAPET TF, TECAFORM AD AF) frequently exhibit slightly lower mechanical strength. Due to this PTFE content, several aspects should be remembered when processing.

ⓘ Pay attention to the following when machining these materials:

- Materials tend to lag behind the milling tool
 - ↳ There is a distinct increase in surface roughness (hair formation, spikes, rough surface)

- Avoid re-cutting with the milling machine
 - ↳ Also leads to rougher surfaces
- A further “re-cutting process” may be necessary in order to smooth spikes to the desired surface quality
- De-burring is often also necessary
- Select a suitable tension, in order to avoid the component “dying away” and as a result components that are not true to size.

TECASINT

Polyimide products produced by a sintering process

The TECASINT product groups 1000, 2000, 3000, 4000 and 5000 can be processed dry or wet on standard metal working machinery.

ⓘ Recommendations

Tools

- Use fully hardened metal tools
- Tools with a cutting angle as used for aluminium processing are very suitable
- For highly filled TECASINT products with e.g. glass fibres, glass beads, use tools fitted with diamond or ceramic tips

Processing

- High cutting speeds and low feed rates coupled with dry machining improve the result
- Wet processing increases the cutting pressure and promotes the formation of flash, but is recommended to extend the tool life
- Synchronous milling to prevent chipping and cavities
- Intermediate tempering is normally not necessary

ⓘ Due to the increased tendency of polyimides to absorb moisture, it is advisable to seal these parts in a vacuum barrier film. In order to avoid dimensional changes to very high quality parts due to moisture absorption, these are opened just before use.

Fibre reinforced TECA materials

Fibre reinforced materials include all types of fibres.

We are concentrating on the most important products in these machining recommendations, including carbon-fibre reinforced products (amongst others, TECAPEEK GF30, TECAPEEK CF30, TECAPEEK PVX, TECATRON GF40, TECTRON PVX, TECAMID 66 GF30, TECAMID 66 CF20) and glass-fibre reinforced products.

Recommendations

Tooling

- Use hardened steel tools (carbide steel K20) in any case, or ideally polycrystalline diamond tooling (PCD)
- Use very well sharpened tools
- Regular control checks of tools, due to the abrasive effects of the materials
 - ↳ Higher standing times
 - ↳ Avoid too much temperature input

Clamping semi-finished goods

- Clamp in the extrusion direction (highest compression strength)
- Use the lowest possible tensions
 - ↳ Avoid sagging and flexural strain
 - ↳ Reduced warping and/or the danger of tension cracking in the component

Pre-heating

- Pre-heating of semi-finished goods may be recommended for their further processing
 - ↳ Greater material durability
- Semi-finished goods should be moderately heated for this purpose
- We recommend a heating rate of 20 °C per hour to 80 – 120 °C.
- For even temperature distribution in the semi-finished goods cross-section, we also recommend a holding time of at least 1 hour per 10 mm wall thickness.
- At this temperature, the semi-finished parts should be prefabricated with oversize

- Final manufacture after cooling down to room temperature
- Tooling should also be heated before processing
 - ↳ Avoid heat dissipation from the material

Processing

- Even fly-cutting of the bilateral edge zones of the semi-finished part:
 - ↳ Ideally, each fly-cutting process should have a max. cutting depth of 0.5 mm
 - ↳ Results in more homogenous distribution of tension in the semi-finished part
 - ↳ Leads to a higher quality of the component

Example

We recommend, for example, with final dimensions of 25 mm to use a 30 mm thick sheet, which is to be fly cut 2 mm on both sides prior to machining. In this case, the sheet should be turned over several times and max. 0.5 mm removed per working step. Ideally, this preliminary work should be carried out on a pre-warmed semi-finished part. Subsequently, the final processing is carried out on the cooled, pre-processed product. This process ensures in any case an optimal component quality with low tension and minimum warping of the component.

Key facts at a glance

For better tooling stand times and dimensional stability, the use of carbide steel or PCD tools is recommended with fibre reinforced materials.

Special case TECATEC

Composite

TECATEC is a composite based on a polyarylether ketone with 50 and / or 60 % by weight carbon fibre fabric. The machining of TECATEC is considerably more complex than the machining of short fibre-reinforced products. Due to the layer structure of the material, incorrect machining can lead to different effects:

- Edge chipping
- De-lamination
- Fringing
- Breaking through of fibres

For this reason, specific processing is required for this material. This has to be established case for case, according to the component in question.

Design of semi-finished goods

The suitability of TECATEC for a certain use and the quality of the finished part primarily depends upon the position of the component in the semi-finished part. In the development phase, the directionality of the fibre fabric must already be urgently considered, especially with regard to the type of load (pulling, compression, bending) on the application and the later machine processing.

Machining tools and tooling materials

For higher standing times in comparison to HSS or carbide steel tools, we recommend the use of

- PCD tools (polycrystalline diamond)
- Ceramic tools
- Titanium coated tools
- Tools with functional coatings (plasma technology)

Besides higher standing times, these tools help to minimise the feed forces, when the specific material is also considered in the design.

- Select a moderate cutting sharpness
- Establish a good balance between surface quality (with very sharp blades) and tooling standing times (blunter cutting blades)
- Design milling geometries so that the fibres are cut. Otherwise there is a danger of fibre fringing
- Due to the higher abrasiveness of the carbon fibres, regular changing of the TECATEC tools is necessary
 - ↳ Avoid too much heat input and warping due to blunt tools

Machining

- There is a greater risk of chipping and burr formation during the machining process with the fibres running parallel to the woven fabric than when processing is vertically to the woven fabric
- For narrower tolerances, the components can also be tempered several times during manufacture
- Due to relatively good heat dissipation thanks to the higher fibre content, good heat distribution in the work piece can be expected. For this reason, we recommend that the material be dry machined.

Machining and tooling parameters

We recommend that attention is paid to the following parameters:

- Avoid using high feed forces
- Very high point angles (150 – 180°)
- Very low feed rates (approx. < 0,05 mm/min)
- High cutting rates (approx. 300 – 400 m/min)

This information is intended to provide initial assistance in the machining of TECATEC - detailed information depends on the individual case.

Machining errors – causes and solutions

Cutting and sawing

<i>Difficulties</i>	<i>Root causes</i>
Surface has started to melt	<ul style="list-style-type: none"> → Blunt tool → Insufficient lateral play / clearance → Insufficient coolant feed
Rough surface	<ul style="list-style-type: none"> → Feed rate too high → Tool unprofessionally sharpened → Cutting edge not honed
Spiral marks	<ul style="list-style-type: none"> → Tool friction during withdrawal → Burr on the tool
Concave and convex surfaces	<ul style="list-style-type: none"> → Point angle too great → Tool not vertical relative to the spindle → Tool is deflected → Feed rate too high → Too mounted above or below the centre
"Stumps" or burr at the end of the cutting surface	<ul style="list-style-type: none"> → Point angle not large enough → Blunt tool → Feed rate too high
Burr on the outside diameter	<ul style="list-style-type: none"> → Blunt tool → No space in front of the cutting diameter

Turning and milling

<i>Difficulties</i>	<i>Root causes</i>
Surface has started to melt	<ul style="list-style-type: none"> → Blunt tool or shoulder friction → Insufficient lateral play / clearance → Feed rate too low → Spindle speed too high
Rough surface	<ul style="list-style-type: none"> → Feed rate too high → Incorrect clearance → Sharp point at the tool (slight radius on point of milling cutter required) → Tool not centrally mounted
Burr on corners of cutting edge	<ul style="list-style-type: none"> → No space in front of the cutting diameter → Blunt tool → Insufficient lateral play / clearance → No lead angle at the tool
Cracks or flaking at the corners	<ul style="list-style-type: none"> → Too much positive inclination at the tool → Tools not sufficiently run-in (action of tool is too hard on the material) → Blunt tool → Tool mounted under the centre → Sharp point at the tool (slight radius on point of milling cutter required)
Chatter marks	<ul style="list-style-type: none"> → Excessive radius on point of milling cutter at the tool → Tool not sufficiently firmly mounted → Insufficient material guidance → Cutting edge width too great (use 2 cuts)

Drilling

<i>Difficulties</i>	<i>Root causes</i>
<i>Tapered drill holes</i>	<ul style="list-style-type: none"> → Incorrectly sharpened drill bits → Insufficient play / clearance → Excessively high feed rate
<i>Burnt or melted surface</i>	<ul style="list-style-type: none"> → Use of unsuitable drill bits → Incorrectly sharpened drill bits → Insufficient feed rate → Blunt drill bit → Land too thick
<i>Surface splitting</i>	<ul style="list-style-type: none"> → Excessive feed rate → Excessive play / clearance → Excessive incline (thin land as described)
<i>Chatter marks</i>	<ul style="list-style-type: none"> → Excessive play / clearance → Insufficient feed rate → Drill overhang too great → Excessive incline (thin land as described)
<i>Feed marks or spiral lines at the inside diameter</i>	<ul style="list-style-type: none"> → Excessively high feed rate → Drill not centred → Drill tip not in centre
<i>Overdimensioned drill holes</i>	<ul style="list-style-type: none"> → Drill tip not in centre → Land too thick → Insufficient play / clearance → Excessively high feed rate → Drill point angle too great
<i>Underdimensioned drill holes</i>	<ul style="list-style-type: none"> → Blunt drill bit → Excessive play / clearance → Drill point angle too small

<i>Difficulties</i>	<i>Root causes</i>
<i>Nonconcentric drill holes</i>	<ul style="list-style-type: none"> → Excessively high feed rate → Spindle speed too low → Drill penetrates too far into next part → Parting-off tool leaves "stump" which deflects the drill bit → Land too thick → Drilling speed too high at the start → Drill not clamped centrally → Drill not correctly sharpened
<i>Burr left after parting off</i>	<ul style="list-style-type: none"> → Blunt cutting tools → Drill does not travel completely through the part
<i>Drill quickly becomes blunt</i>	<ul style="list-style-type: none"> → Feed rate too low → Spindle speed too low → Insufficient lubrication due to cooling

Key facts at a glance

Please do not hesitate to contact our technical application advise service for technical information: techservice.shapes@de.ensinger-online.com or by telephone on Tel. +49 7032 819 101

Ensinger Germany

Ensinger GmbH
Rudolf-Diesel-Straße 8
71154 Nufringen
Tel. +49 7032 819 0
Fax +49 7032 819 100
www.ensinger-online.com

Ensinger GmbH
Mercedesstraße 21
72108 Rottenburg a. N.
Tel. +49 7457 9467 100
Fax +49 7457 9467 122
www.ensinger-online.com

Ensinger GmbH
Wilfried-Ensinger-Straße 1
93413 Cham
Tel. +49 9971 396 0
Fax +49 9971 396 570
www.ensinger-online.com

Ensinger GmbH
Borsigstraße 7
59609 Anröchte
Tel. +49 2947 9722 0
Fax +49 2947 9722 77
www.ensinger-online.com

Ensinger GmbH
Mooswiesen 13
88214 Ravensburg
Tel. +49 751 35452 0
Fax +49 751 35452 22
www.thermix.de

Ensinger worldwide

Austria
Ensinger Sintimid GmbH
Werkstraße 3
4860 Lenzing
Tel. +43 7672 7012800
Fax +43 7672 96865
www.ensinger-sintimid.at

Brazil
Ensinger Indústria de
Plásticos Técnicos Ltda.
Av. São Borja 3185
93.032-000 São Leopoldo-RS
Tel. +55 51 35798800
Fax +55 51 35882804
www.ensinger.com.br

China
Ensinger (China) Co., Ltd.
1F, Building A3
No. 1528 Gumei Road
Shanghai 200233
P.R.China
Tel. +86 21 52285111
Fax +86 21 52285222
www.ensinger-china.com

Czech Republic
Ensinger s.r.o.
Průmyslová 991
P.O. Box 15
33441 Dobřany
Tel. +420 37 7972056
Fax +420 37 7972059
www.ensinger.cz

Denmark
Ensinger Danmark A/S
Rugvænget 6B
4100 Ringsted
Tel. +45 7810 4410
Fax +45 7810 4420
www.ensinger.dk

France
Ensinger France S.A.R.L.
ZAC les Batterses
ZI Nord
01700 Beynost
Tel. +33 4 78554574
Fax +33 4 78556841
www.ensinger.fr

India
Ensinger India Engineering
Plastics Private Ltd.
R.K Plaza, Survey No. 206/3
Plot No. 17, Lohgaon,
Viman Nagar
411 014 Pune
Tel. +91 20 2674 1033
Fax +91 20 2674 1001
www.ensinger.in

Italy
Ensinger Italia S.r.l.
Via Franco Tosi 1/3
20020 Olcella di Busto
Garolfo
Tel. +39 0331 568348
Fax +39 0331 567822
www.ensinger.it

Japan
Ensinger Japan Co., Ltd.
3-5-1, Rinkaicho,
Edogawa-ku, Tokyo
134-0086, Japan
Tel. +81 3 5878 1903
Fax +81 3 5878 1904
www.ensinger.jp

Poland
Ensinger Polska Sp. z o.o.
ul. Geodetów 2
64-100 Leszno
Tel. +48 65 5295810
Fax +48 65 5295811
www.ensinger.pl

Singapore
Ensinger International GmbH
(Singapore Branch)
63 Hillview Avenue # 04-07
Lam Soon Industrial Building
Singapore 669569
Tel. +65 65524177
Fax +65 65525177
www.ensinger.com.sg

Spain
Ensinger S.A.
Girona, 21-27
08120 La Llagosta
Barcelona
Tel. +34 93 5745726
Fax +34 93 5742730
www.ensinger.es

Sweden
Ensinger Sweden AB
Stenvretsgatan 5
SE-749 40 Enköping
Tel. +46 171 477 050
Fax +46 171 440 418
www.ensinger.se

United Kingdom
Ensinger Limited
Wilfried Way
Tonyrefail
Mid Glamorgan CF39 8JQ
Tel. +44 1443 678400
Fax +44 1443 675777
www.ensinger.co.uk

USA
Ensinger Inc.
365 Meadowlands Boulevard
Washington, PA 15301
Tel. +1 724 746 6050
Fax +1 724 746 9209
www.ensinger-inc.com



Thermoplastic engineering and high-performance plastics from Ensinger are used in almost every important sector of industry today. Their economy and performance benefits have seen them frequently supplant classically used materials.

AUCKLAND:

Unit 23, 761 Great South Road,
Penrose, Auckland 1061

P: +64 9 589 1705

E: sales.akl@supplyservices.co.nz

MT MAUNGANUI (HQ):

67 Newton St,
Mt Maunganui 3116

P: +64 7 575 0125

E: sales.mtm@supplyservices.co.nz

CHRISTCHURCH:

11 Dakota Cres, Sockburn,
Christchurch 8042

P: +64 3 341 7200

E: sales.chc@supplyservices.co.nz