

**FB**

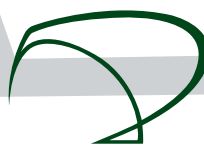

**SUPPLY SERVICES LTD**



Phone 0800 102 112 - [www.supplyservices.co.nz](http://www.supplyservices.co.nz)

**FB Ketjutekniikka Oy**

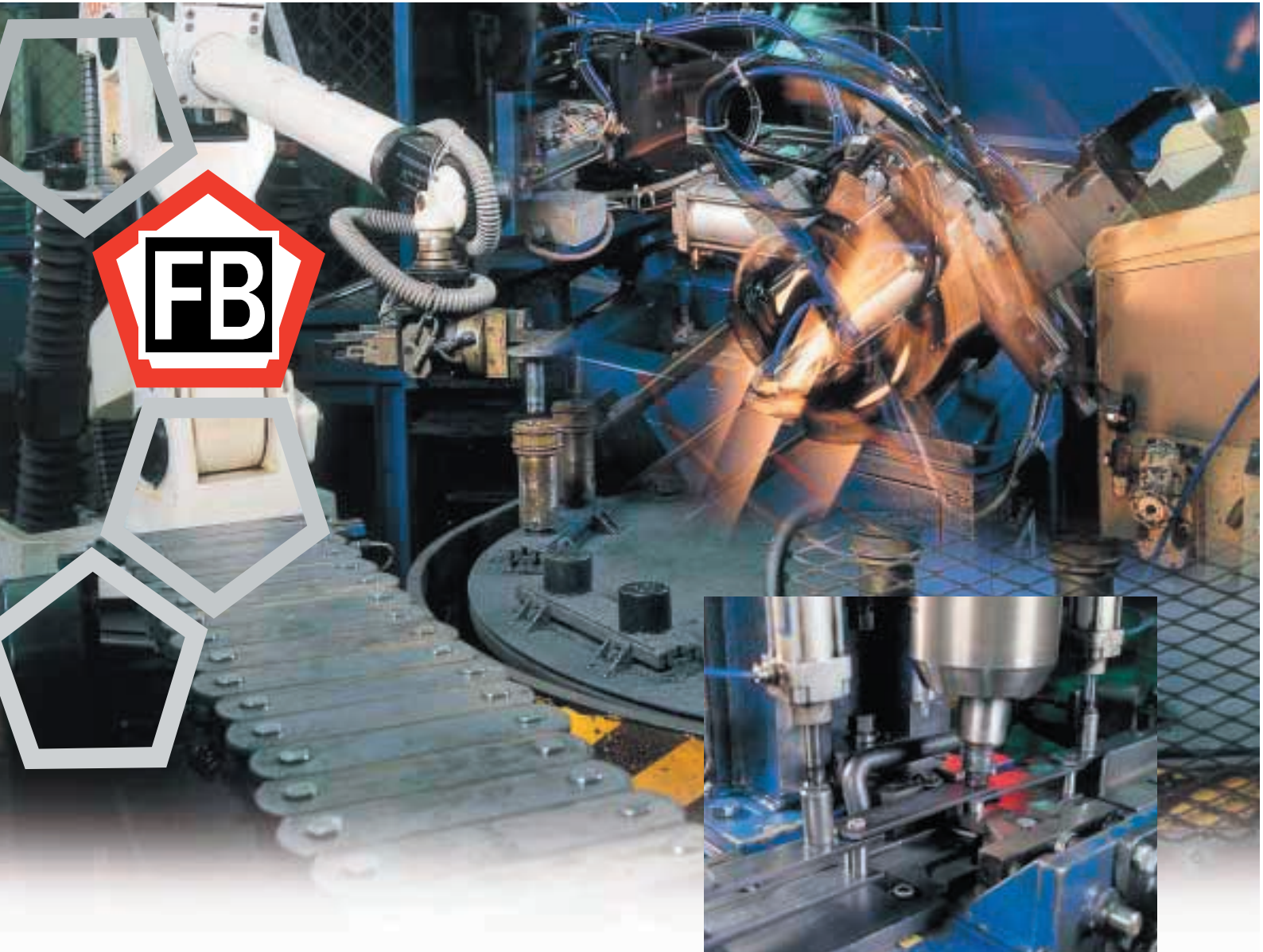

## GREAT KNOWHOW

FB Ketjutekniikka is the largest manufacturer of conveyor chains in Scandinavia. With over 50 years of experience and specialisation in conveyor chains FB Ketjutekniikka has developed into one of the leading companies in the industry. The conveyor chains manufactured by FB Ketjutekniikka are sold to companies throughout the world with a particularly strong presence in Scandinavia and Europe.

## CONVEYOR CHAIN SUITING MANY APPLICATIONS

The very wide product range offered by FB Ketjutekniikka includes conveyor chains according to various standards as well as special chains, chain wheels and different kind of attachments. For even for the most demanding application the best possible solution can be found from a combination of these products. Special solutions can also be developed together with the customer for particularly individual needs.



## HIGH QUALITY

FB Ketjutekniikka has always invested heavily in quality and reliability. As a result of this determination FB Ketjutekniikka in 1993 became the first chain manufacturer in Scandinavia to be fully accredited to SFS-EN ISO 9001 certification. The consistent high quality is an advantage for the customer – a durable, reliable conveyor is a profitable investment.





## **SPECIAL KNOWHOW AND OWN PRODUCT DEVELOPMENT**

Many conveyor designers and users are familiar with the light and strong FB Profile Chain, which is a result of our own product development. Continuous work in product development has enabled FB Ketjutekniikka to meet customer demands for new and replacement conveying applications.

## **MODERN PRODUCTION TECHNOLOGY**

FB Ketjutekniikka Oy has made high levels of investment in the most up-to-date technology of welding, machining and robotic technology in assembly. This guarantees effective and flexible production and combined with the on-line production management system enables precise and uniform products delivered on time.

## **ENVIRONMENTAL ASPECT**

FB Ketjutekniikka Oy uses high quality raw materials which can be recycled. Production machining chips and other waste steel is collected and recycled. The chains are lubricated with an environmental friendly, rape seed oil based, special conveyor chain lubricant. All packaging is totally made of recyclable materials.

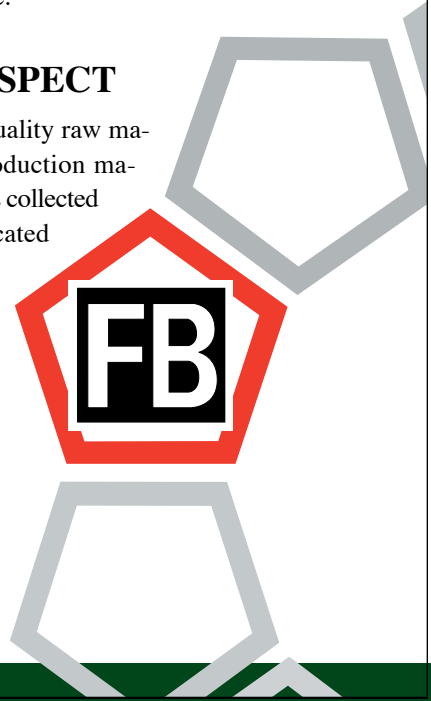

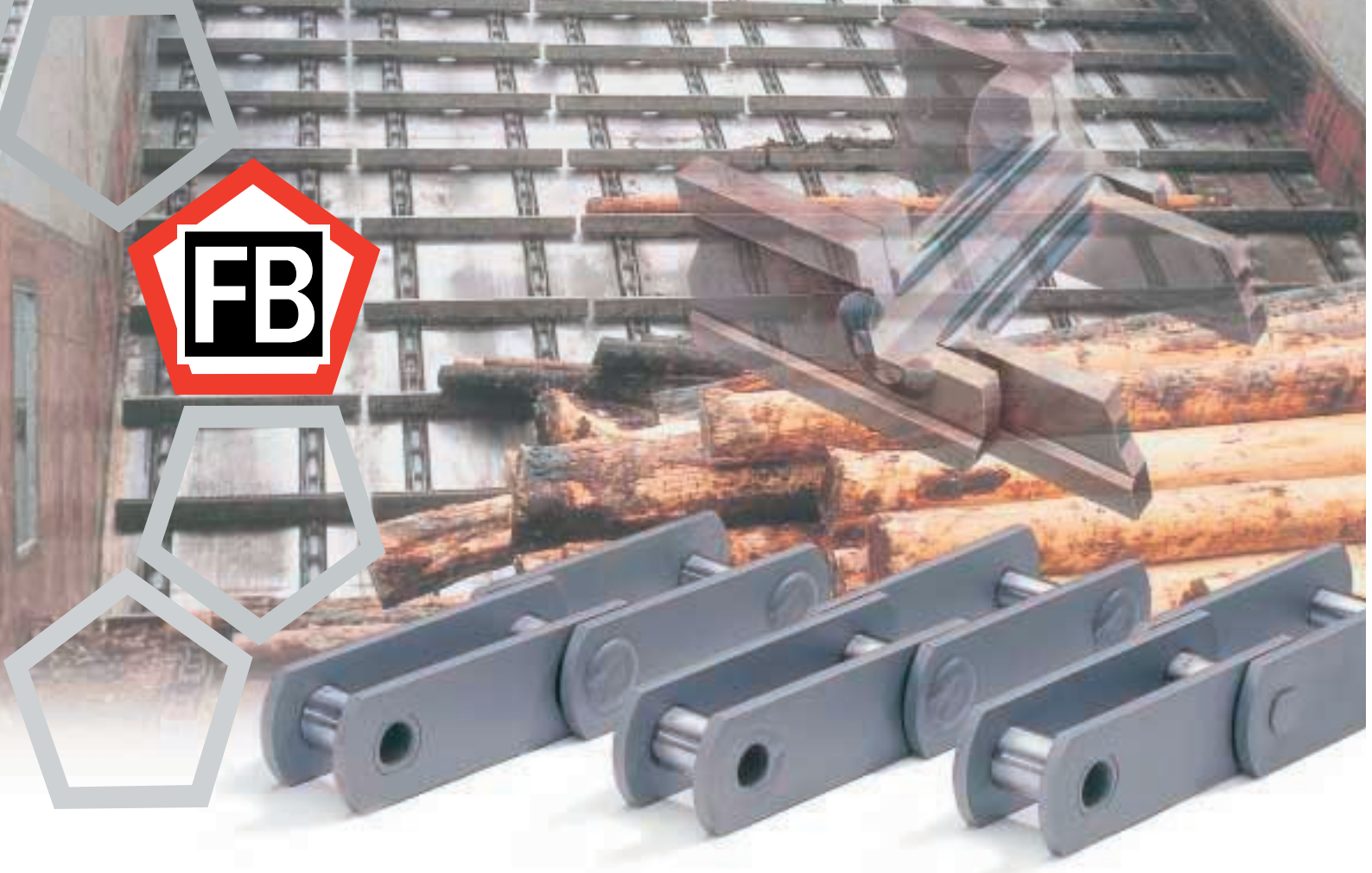

## CHOOSE THE RIGHT CHAIN FOR THE RIGHT PLACE

FB conveyor chains are constructed to withstand the most arduous applications. The chain's characteristics are attained by surface hardened, homogenous and accurate pins and bushes with locating shoulders. The holes in the sideplates are made by special precision punching resulting in a perfect cylindrical hole formation. These characteristics together with a press fit between pins, bushes and sideplates makes the strongest joint possible.

### ROUND RIVETED CHAINS

The bushes are connected to the inner plates by a cold riveting method. The pins are spun riveted, which is also a cold riveting method, in which an automatic machine eccentrically works the ends of the pins with a high compression force to the outerplates. A very strong and side-ways impact resistant joint is achieved by this procedure. This is acknowledged to be the best method of riveting and is superior for small chains.

### CHAINS WITH WELDED PINS

The bushes are connected to the inner plates by a cold riveting method in the same way as in round riveted chains. The pins are welded by CNC-automatic welding machines with high and consistent quality.

Furthermore, welded pins increases the life of the chain. The chain is very stable and wear resistant to the exceptional forces seen in some arduous applications. The special steels used in FB chains are all fully weldable.

### CHAINS WITH WELDED PINS AND BUSHES

Both the pins and bushes are welded to the side plates. The welding is made by CNC-automatic welding machines to guarantee high and consistent quality. This alternative is considered the best in the most demanding applications. With welded pins and bushes the chain achieves about 30% higher breaking load compared to the same dimensioned standard chain with riveted construction.

### PROFILE CHAIN

The internationally patented profile chain is the result of our ongoing research and development by FB Ket-jutekniikka. Profile chain has been designed and developed for the most demanding and difficult applications commonly found in the timber log handling and paper industries, but can also be used in other kind of demanding applications. Profile chain is lighter than comparable standard chain and offers greater resistance to wear and shock loadings together with increased fatigue life.

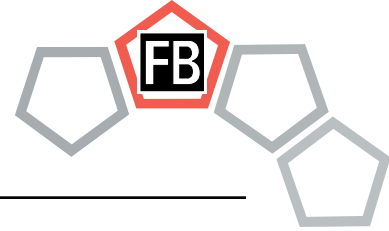

# PROFILE CHAIN

## A Without rollers

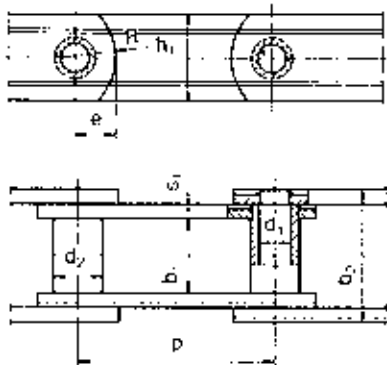

## B With small rollers

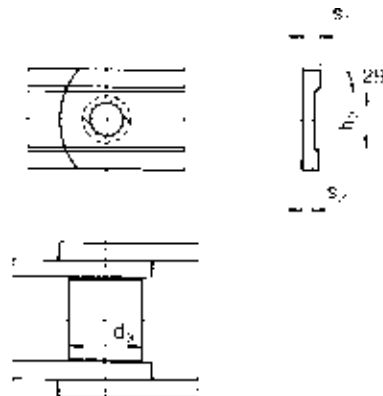

### Ordering code:

Profile chain - type - pitch

Example: Profile chain P50 - A - 200

### Note!

Chains are supplied with welded connecting links.

If a plastic sliding track is used, side plates edges must be rounded off. (Please mention when ordering.)

Chain No.	Breaking load kN	Pitch p	Pin d <sub>1</sub>	Bush d <sub>2</sub>	Small roller d <sub>3</sub>	Inner width b <sub>1</sub>	Outer width b <sub>2</sub>	Sideplates						Bearing surface*		Weight kg/m	
								h <sub>1</sub>	h <sub>2</sub>	s <sub>1</sub>	s <sub>2</sub>	e	R	cm <sup>2</sup>	A	B	
P35	350	160	22	34	45	55	99	60	35	10	6,5	28	50	16,4	12,4	14,2	
		200													11,3	12,7	
P50	500	160	26	40	55	65	117	70	40	12	8,0	33	50	23,0	18,9	22,4	
		200													17,3	20,1	
P75	750	200	32	48	65	80	143	85	50	15	10,0	40	55	35,0	27,4	32,3	
		250													24,8	28,8	

\*Bearing surface =  $d_1 \times (b_1 + 2s_1)$

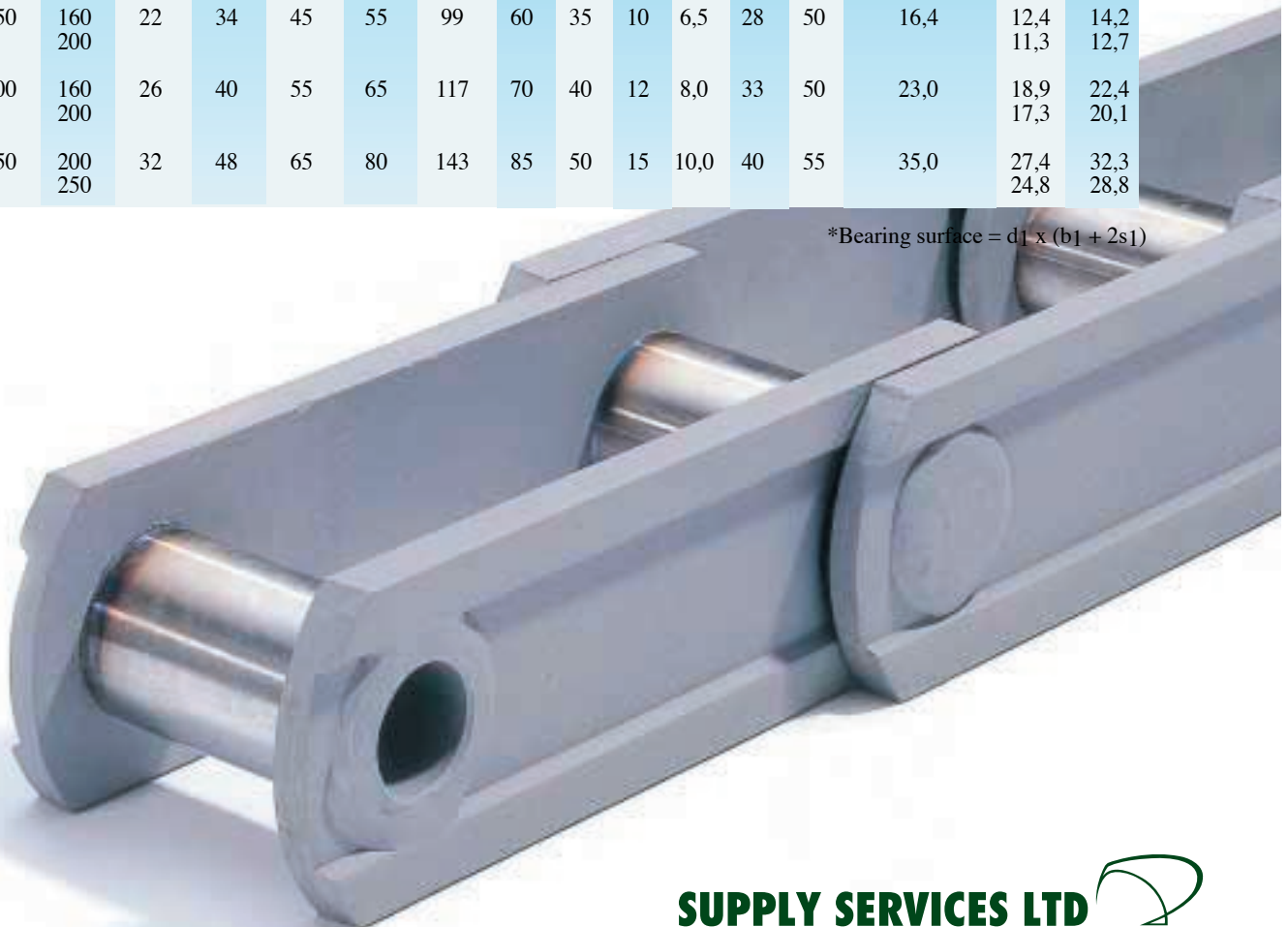

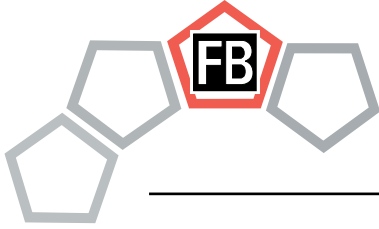

# CONVEYOR CHAINS

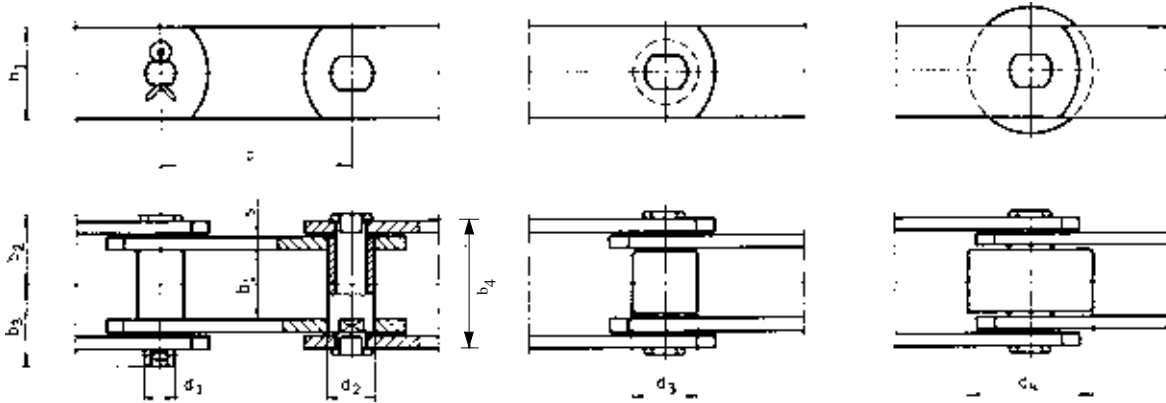

**A Without rollers**

**B With small rollers**

**C With plain rollers**

Order designation:

Conveyor chain, chain number - type - pitch

Example: Conveyor chain M80 - C - 100

Chain No.	Pitch				Inner width $b_1$	Pin $d_1$	Bush $d_2$	Small roller $d_3$	Plain roller $d_4$	Flanged roller			$b_2$	$b_3$	$b_4$	Sideplates		
	$p$									$d_5$	$e$	$s$				$h_1$	$h_2$	$h_3$
<b>M 40</b>	63	80	100	125	20	8,5	12,5	18	36	42	13,5	21	24	37	*4	25	35	22,5
<b>M 56</b>	63	80	100	125	24	10	15	21	42	50	17	24	27	41	4	30	45	25
<b>M 80</b>	80	100	125	160	28	12	18	25	50	60	20	29	33	49	5	35	50	32,5
<b>M 112</b>	80	100	125	160	32	15	21	30	60	70	22	33	37	57	6	40	60	40
<b>M 160</b>	100	125	160	200	37	18	25	36	70	85	25,5	38	43	67	7	50	70	45
<b>M 224</b>	125	160	200	250	43	21	30	42	85	100	30	44	49	77	8	60	90	60
<b>M 315</b>	160	200	250	315	48	25	36	50	100	120	33	51	58	90	10	70	100	65
<b>M 450</b>	200	250	315	400	56	30	42	60	120	140	37	60	66	107	12	80	120	80
<b>M 630</b>	250	315	400	500	66	36	50	70	140	170	45	69	78	126	14	100		
<b>M 900</b>	250	315	400	500	78	44	60	85	170	210	52	79	89	146	16	120		

\*deviation to DIN 8167 and ISO/R 1977 -standards

Please note!

The chains are supplied with welded or riveted connecting pins, unless otherwise specified when ordering.

To be specified with order:

- Length of the chain in meters (or in number of links)
- Order designation of chain (chain no. - type - pitch)
- Connecting pins fastening (with rivet, split pin or welded)
- Plain roller: special material requirements (if for example plastic)
- Lubrication: special requirements

If a plastic sliding track is used, side plates edges must be rounded off.  
(Please mention when ordering.)



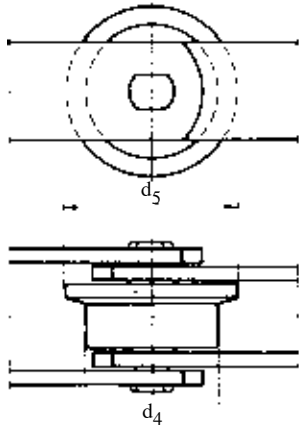
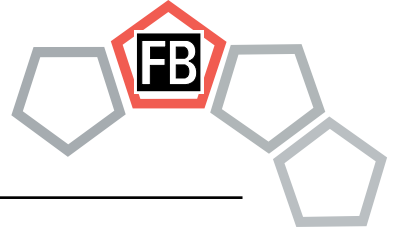

**D With flanged rollers**

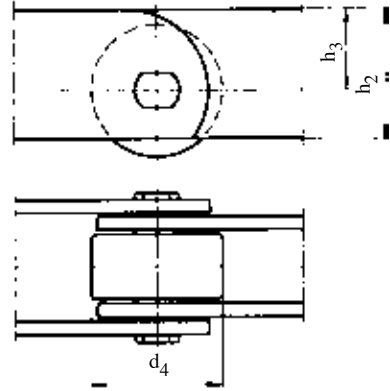
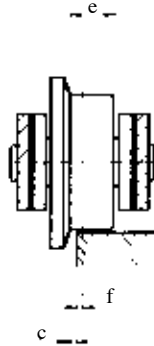

**E With deep link sideplates**

Chain No.	Breaking load kN	Maximum allowed load N	Measuring load N	Bearing surface $a_k$ (cm <sup>2</sup> )	Plain roller Bearing surface $a_r$ (cm <sup>2</sup> )	f	c
<b>M 40</b>	40	5700	800	2,30	2,38	3,5	1
<b>M 56</b>	56	8000	1120	3,20	3,45	4,5	1,5
<b>M 80</b>	80	11400	1600	4,58	4,86	5	2
<b>M 112</b>	112	16000	2240	6,63	6,51	5	2,5
<b>M 160</b>	160	22800	3200	9,22	9,00	5,5	3
<b>M 224</b>	224	32000	4500	12,47	12,60	7	3
<b>M 315</b>	315	45000	6300	17,10	16,92	7,5	3
<b>M 450</b>	450	64000	9000	24,18	23,10	8	3,5
<b>M 630</b>	630	90000	12500	34,06	32,50	11	3,5
<b>M 900</b>	900	128000	18000	48,66	45,69	13,5	3,5

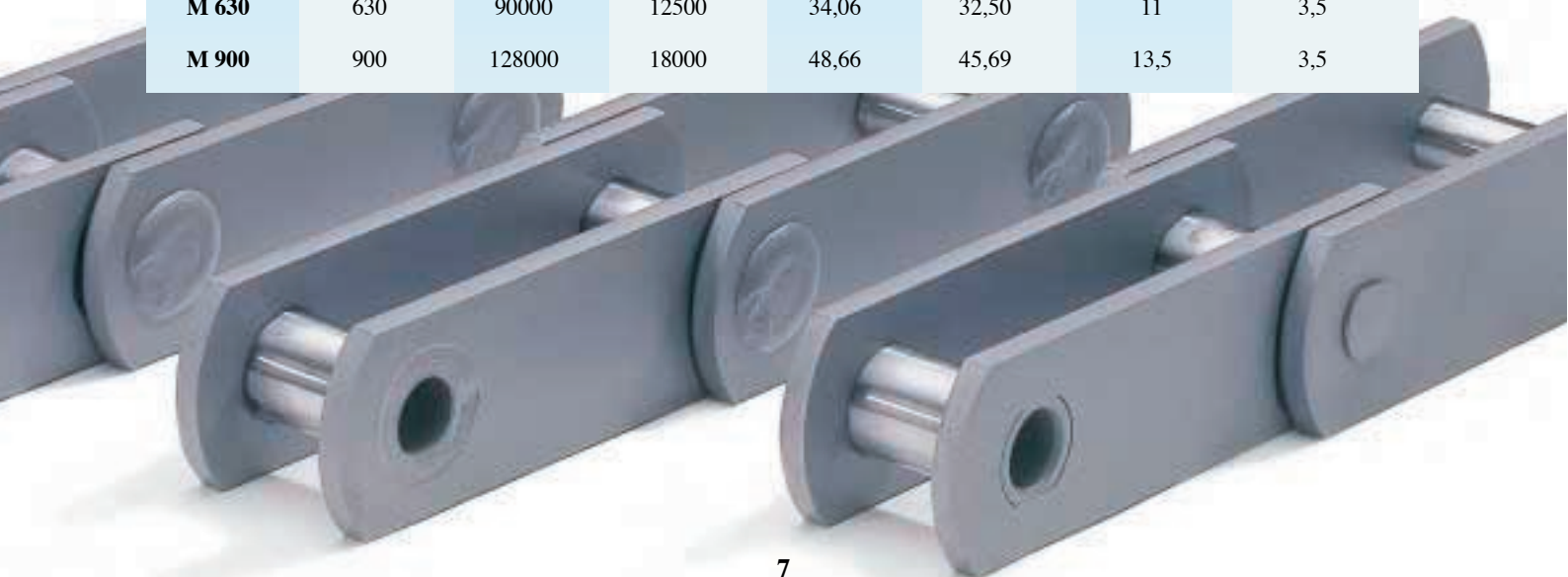

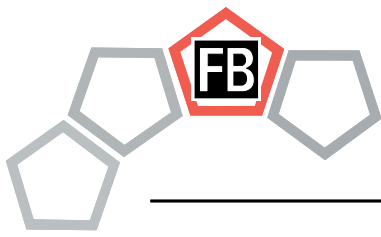

# CONVEYOR CHAINS

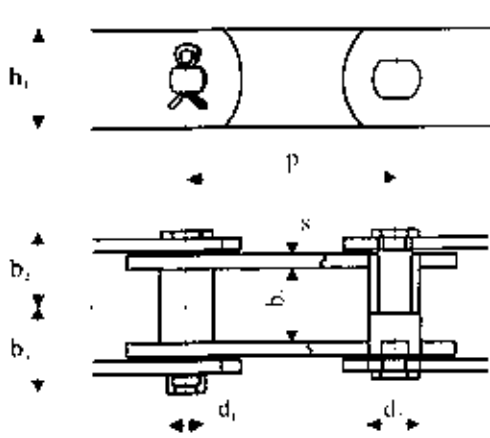

**A Without rollers**

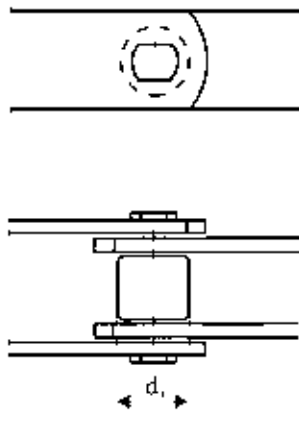

**B With small rollers**

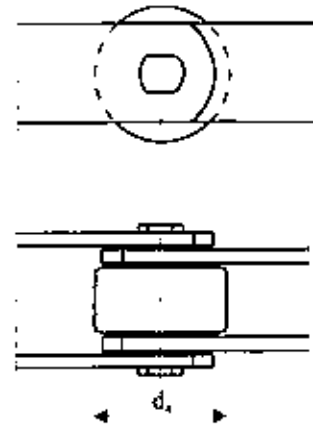

**C With plain rollers**

Order designation:

Conveyor chain, chain number - type - pitch

Example: Conveyor chain FV90 - C - 100

Chain No.	Breaking load kN	Maximum allowed load N	Pitch p	Inner width b <sub>1</sub>	Pin d <sub>1</sub>	Bush d <sub>2</sub>	Small roller d <sub>3</sub>
<b>FV 40</b>	40	6700	40 63 80 100	18	10	15	20
<b>FV 63</b>	63	10500	63 100 125 160	22	12	18	26
<b>FV 90</b>	90	15000	63 100 125 160	25	14	20	30
<b>FV 112</b>	112	18700	100 125 160 200	30	16	22	32
<b>FV 140</b>	140	23400	100 125 160 200	35	18	26	36
<b>FV 180</b>	180	30000	125 160 200 250	45	20	30	42
<b>FV 250</b>	250	41700	125 160 200 250	55	26	36	50
<b>FV 315</b>	315	52500	160 200 250 315	65	30	42	60
<b>FV 400</b>	400	66700	160 200 250 315	70	32	44	60
<b>FV 500</b>	500	83400	160 200 250 315	80	36	50	70
<b>FV 630</b>	630	105000	200 250 315 400	90	42	56	80



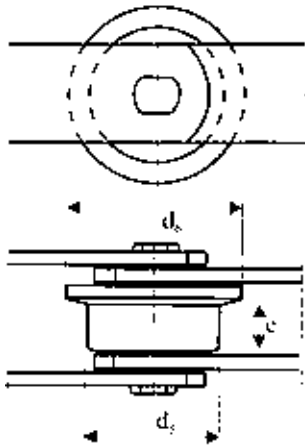
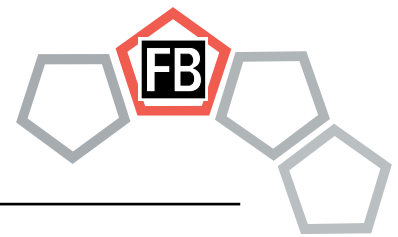

**D With flanged rollers**

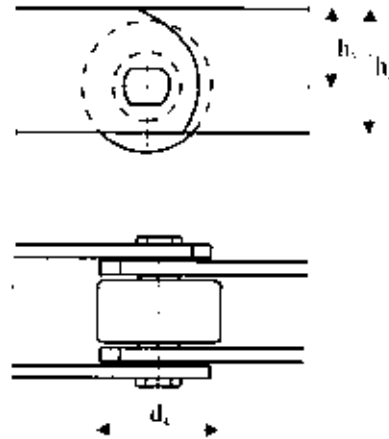

**E With deep link sideplates**

Chain No.	Plain roller $d_4$	Flanged roller		Sideplates					
		$d_5$	$d_6$	$b_2$	$b_3$	$s$	$h_1$	$h_2$	$h_3$
<b>FV 40</b>	32	40	48	18,5	22	*4	25	35	22
<b>FV 63</b>	40	50	60	23	27,5	4	30	40	25
<b>FV 90</b>	48	63	73	26,5	31	5	35	45	27,5
<b>FV 112</b>	55	72	87	31,5	36	6	40	50	30
<b>FV 140</b>	60	80	95	34	40	6	45	60	37,5
<b>FV 180</b>	70	100	120	43	50	8	50	70	45
<b>FV 250</b>	80	125	145	49	57	8	60	80	50
<b>FV 315</b>	90	140	170	58,5	66,5	10	70	90	55
<b>FV 400</b>	100	150	185	65,5	75,5	12	70	90	55
<b>FV 500</b>	110	160	195	70,5	80,5	12	80	100	60
<b>FV 630</b>	120	170	210	76,5	86,5	12	100	120	70

\*deviation to DIN 8165

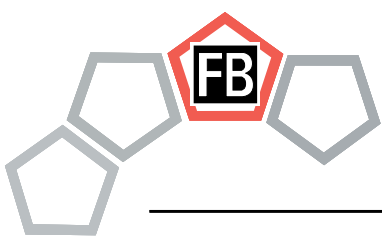

# CONVEYOR CHAINS SMS 1698

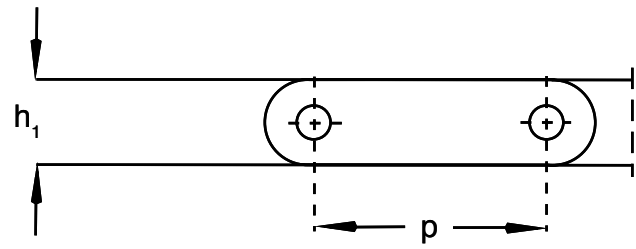

**A Without rollers**

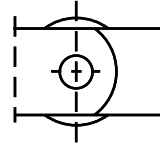

**B With plain rollers**

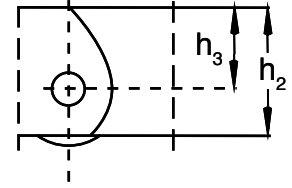

**E With deep link sideplates**

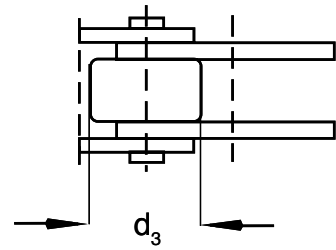
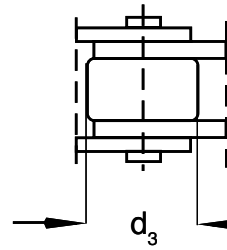
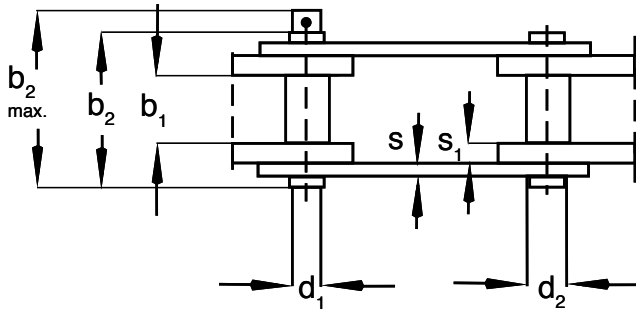

Chain No.	Breaking load kN	Pitch p mm	Inner width b <sub>1</sub> mm	Pin d <sub>1</sub> mm	Bush d <sub>2</sub> mm	Roller d <sub>3</sub> mm	Sideplates				Outer sideplates		Length of bin b <sub>2</sub> mm
							h <sub>1</sub> mm	h <sub>2</sub> mm	h <sub>3</sub> mm	s mm	s mm normal	s mm heavy	
3,5	35	50 63 80 100	18	10	15	32	25	35	22,5	4	4	6	49
5,5	55	50 63 80 100	22	12	18	40	30	40	25	5	4	6	54
8,5	85	63 80 100 150	25	14	20	50	35	50	32,5	6	5	8	65
12,5	125	100 150 200	35	18	26	60	40	60	40	8	6	8	81
18	180	100 150 200 250	45	20	30	70	50	78	45	8	6	10	96
24	240	100 150 200 250	55	26	36	80	60	80	50	10	8	12	116
30	300	150 200 250	65	30	42	90	70	90	55	10	8	12	128
40	400	150 200 250	80	36	50	110	80	110	70	10	12	12	148
65	650	150 200 250	80	36	50	110	90	120	75	12	15	15	158

# ATTACHMENTS AND BRACKETS

Conveyor chain can be combined, in most cases, with different kind of attachments or brackets.

The special steels used in side plates in all FB conveyor chains are well weldable and because of this the attachments can be welded directly to the chains or by screw mounting to welded brackets.

It is preferable for chain to be supplied complete with the attachments, as the welding and handling of greasy chain can often be problematical.

In the factory the attachments are connected to the chain before applying the lubrication resulting in a stronger weld.

Regard has to be made for the space the attachments need on the chain wheel when welding them to the chain.

When chain and chain wheels are dimensioned correctly the attachments can in most cases be attached directly on to the upper surface of the side plates of the conveyor chains.

- FB Ketjutekniikka Oy has standardised various types of mounting holes, brackets as well as bracket pins.
- Some of the most common types of attachments have been standardised by their structure. They are manufactured according to customers' dimensions.
- Naturally FB also delivers any special attachments exactly according to the customer's wishes and drawings.

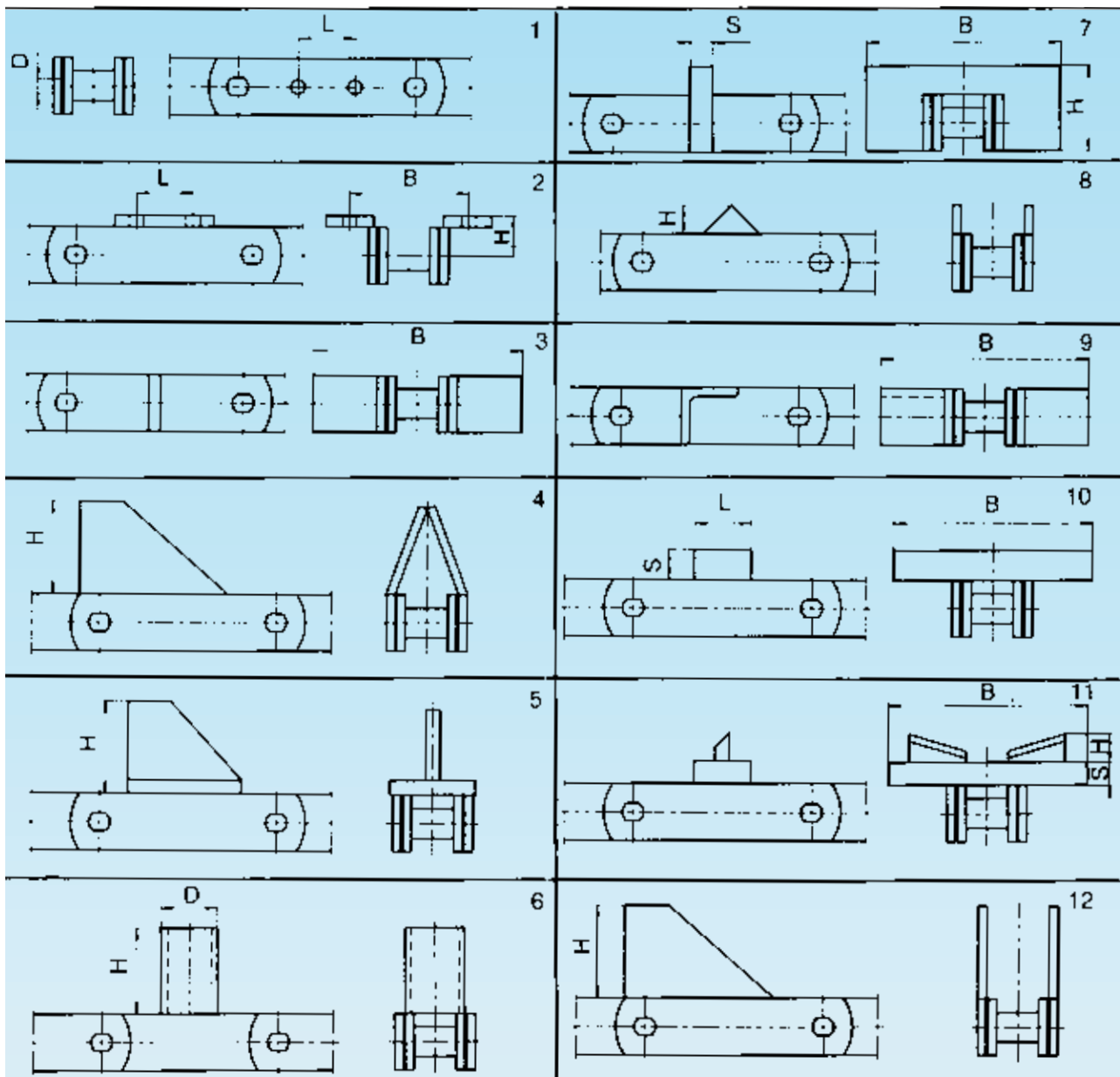

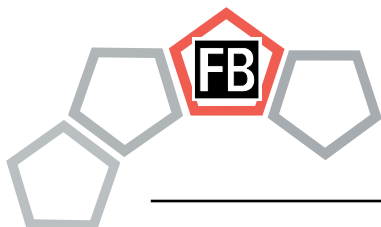

# CHAIN WHEELS

## STANDARD CHAIN WHEEL

Material: Fe 52 C or corresponding special steel  
Keyway: SFS 2636 J9

Construction

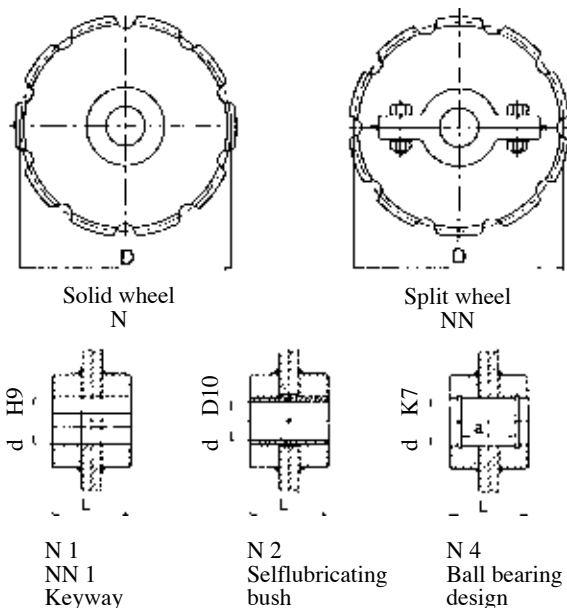

Note! Hubtypes N2 and N4 can only be used in solid wheel.

Ordering designation:  
Chain wheel, hubtype, - number of teeth, - d / conveyor chain  
Example: Chain wheel NN1-8-80/M112-C-125

If wanted some other length of hub or some other material of rim, it must be mentioned in order.

Length of hub

Chain	L	Chain	L
M 40	60	M 315	140
M 56	70	M 450	140
M 80	80		
M 112	100	P 35	140
M 160	110	P 50	140
M 224	120	P 75	160

## CHAIN WHEEL WITH EXTENDED TOOTHGAP

Material: Fe 52 C or corresponding special steel  
Keyway: SFS 2636 J9

Construction

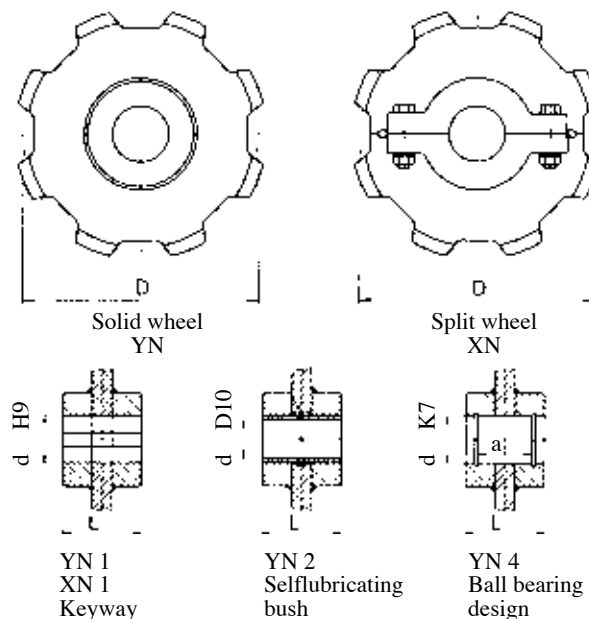

Note! Hubtypes N2 and N4 can only be used in solid wheel.

Ordering designation:  
Chain wheel, hubtype, - number of teeth, - d / conveyor chain  
Example: Chain wheel XN1-8-80/M112-C-125

If wanted some other length of hub or some other material of rim, it must be mentioned in order.

Length of hub

Chain	L	Chain	L
M 160	110		
M 224	120	P 35	140
M 315	140	P 50	140
M 450	140	P 75	160

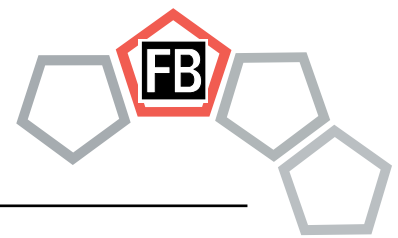

# PITCH CIRCLE DIAMETER

z \ P	40	50	63	80	100	125	160	200	250	315	400	500
6	80,00	100,00	126,00	160,00	200,00	250,00	320,00	400,00	500,00	630,00	800,00	1000,00
7	92,19	115,24	145,20	184,38	230,48	288,10	368,76	460,96	576,20	726,01	921,92	1152,40
8	104,52	130,65	164,62	209,04	261,31	326,63	418,09	522,62	653,27	823,12	1045,24	1306,55
9	116,95	146,19	184,19	233,90	292,38	365,47	467,80	584,76	730,95	920,99	1169,52	1461,90
10	129,44	161,80	203,87	258,88	323,61	404,51	517,77	647,22	809,02	1019,37	1294,44	1618,05
11	141,98	177,47	223,61	283,96	354,95	443,68	567,92	709,90	887,37	1118,09	1419,80	
12	154,54	193,18	243,41	309,09	386,37	482,96	618,19	772,74	965,92	1217,06	1545,48	
13	167,14	208,93	263,25	334,28	417,86	522,32	668,57	835,72	1044,65	1316,25	1671,44	
14	179,76	224,70	283,12	359,52	449,40	561,75	719,04	898,80	1123,50	1415,61		
15	192,38	240,48	303,01	384,77	480,97	601,21	769,55	961,94	1202,42	1515,05		
16	205,03	256,29	322,92	410,06	512,58	640,72	820,12	1025,16	1281,45	1614,62		
17	217,68	272,11	342,85	435,37	544,22	680,27	870,75	1088,44	1360,55	1714,29		
18	230,35	287,94	362,80	460,70	575,88	719,85	921,40	1151,76	1439,70			
19	243,02	303,77	382,75	486,04	607,55	759,43	972,08	1215,10	1518,87			
20	255,70	319,62	402,72	511,40	639,25	799,06	1022,80	1278,50	1598,12			
21	268,38	335,47	422,69	536,76	670,95	838,68	1073,52	1341,90	1677,37			
22	281,06	351,33	442,68	562,13	702,67	878,33	1124,27	1405,34				
23	293,75	367,19	462,66	587,51	734,39	917,98	1175,02	1468,78				
24	306,45	383,06	482,66	612,90	766,13	957,66	1225,80	1532,26				
25	319,14	398,93	502,65	638,29	797,87	997,33	1276,59	1595,74				
26	331,84	414,81	522,66	663,69	829,62	1037,02	1327,39	1659,24				
27	344,55	430,69	542,66	689,10	861,38	1076,72	1378,20	1722,76				
28	357,25	446,57	562,67	714,51	893,14	1116,42	1429,02					
29	369,96	462,45	582,69	739,92	924,91	1156,13	1479,85					
30	382,67	478,34	602,70	765,34	956,68	1195,85	1530,68					

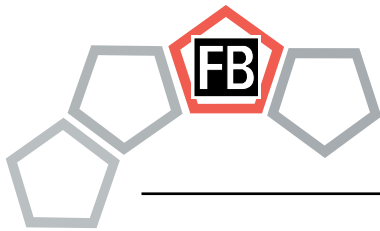

# CONVEYOR CHAIN DIN 8167, ISO/R 1977 WEIGHT TABLE kg/m

Chain No.	Pitch	Type of chain						
		A	B	C		D	E	
				Steel roller	Plastic roller		Steel roller	Plastic roller
<b>M 40</b>	63	2,2	2,5	4,2	2,4	4,3	4,8	3,0
	80	2,0	2,2	3,6	2,2	3,7	4,2	2,8
	100	1,9	2,1	3,1	2,0	3,2	3,7	2,6
	125	1,8	1,9	2,8	1,9	2,9	3,4	2,5
<b>M 56</b>	63	3,2	3,6	6,5	3,6	6,8	7,2	4,3
	80	2,9	3,3	5,5	3,3	5,8	6,2	3,9
	100	2,7	3,0	4,8	3,0	5,0	5,5	3,6
	125	2,6	2,8	4,2	2,8	4,4	4,9	3,4
<b>M 80</b>	80	4,5	5,2	9,0	5,1	9,5	10,3	6,4
	100	4,2	4,7	7,8	4,7	8,1	9,1	6,0
	125	3,9	4,3	6,8	4,3	7,1	8,0	5,5
	160	3,7	4,0	5,9	3,9	6,1	7,1	5,2
<b>M 112</b>	80	6,7	7,7	14,0	7,6	14,6	16,0	9,7
	100	6,1	6,9	11,9	6,8	12,4	14,0	8,9
	125	5,6	6,3	10,3	6,2	10,7	12,3	8,2
	160	5,2	5,8	8,9	5,7	9,2	10,9	7,7
<b>M 160</b>	100	9,5	10,9	18,7	10,4	19,4	19,7	13,1
	125	8,7	9,9	16,1	9,4	16,6	17,3	12,0
	160	8,0	8,9	13,8	8,6	14,2	16,1	11,1
	200	7,5	8,2	12,1	8,0	12,5	14,4	10,4
<b>M 224</b>	125	12,8	14,5	25,6		26,8		
	160	11,6	13,0	21,6		22,6		
	200	10,8	11,9	18,8		19,6		
	250	10,2	11,0	16,6		17,2		
<b>M 315</b>	160	17,8	19,9	33,2		35,1		
	200	16,4	18,1	28,8		30,3		
	250	15,4	16,7	25,2		26,4		
	315	14,5	15,5	22,3		23,2		
<b>M 450</b>	200	23,8	26,8	44,9		46,9		
	250	22,1	24,5	38,9		40,6		
	315	20,6	22,6	34,0		35,3		
	400	19,5	21,0	30,0		31,0		
<b>M 630</b>	250	34,2	38,0	57,4		60,8		
	315	31,7	34,7	50,1		52,8		
	400	29,6	32,0	44,1		46,3		
	500	28,1	30,0	39,7		41,4		
<b>M 900</b>	250	50,7	57,4	97,5		103,9		
	315	46,5	51,7	83,6		88,7		
	400	43,0	47,2	72,2		76,2		
	500	41,5	44,9	64,9		68,1		

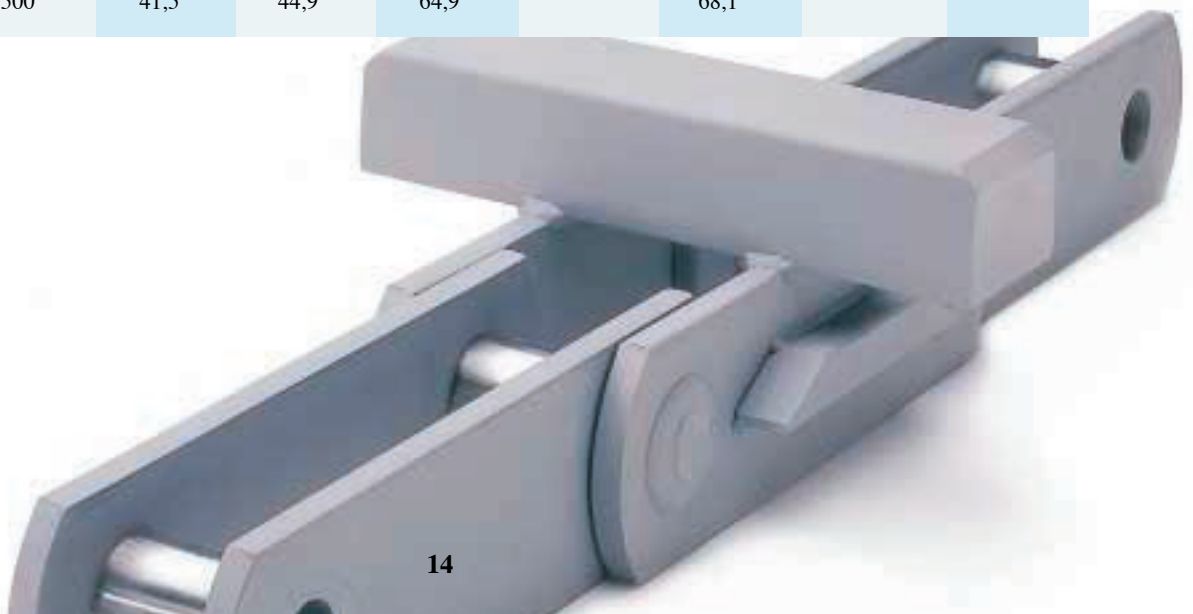

## FB GROUP

FB Group is an international concern concentrated into manufacturing and marketing especially of conveyor chains and special chains for lumber industry. FB Group is a part of Swedish exchange-listed company, Bergman & Beving. We have been operating on chain business since 1912.

FB Group has subsidiary companies in Finland, Sweden, Norway, Denmark, Germany, Austria and Great Britain. The manufacturing of conveyor chains in FB Group takes place in Köyliö, south-western part of Finland by FB Ketjutekniikka Oy. The special, roller chain based, chains for lumber industry are produced in Sweden. The other subsidiaries are mainly concentrated to sell these chain products as well as f.ex. roller and fleyer chains.

The most important customers of FB Group are paper and pulp industry, wood processing industry, energy plants, steel mills, building material industry and conveyor manufacturers.

FB's strategy is to increase the market share of self-produced conveyor chains in European market as well as approve the position of the company itself and its other products in each market area. FB Ketjutekniikka Oy in Finland answers to this challenge by modern production methods and constant product development.

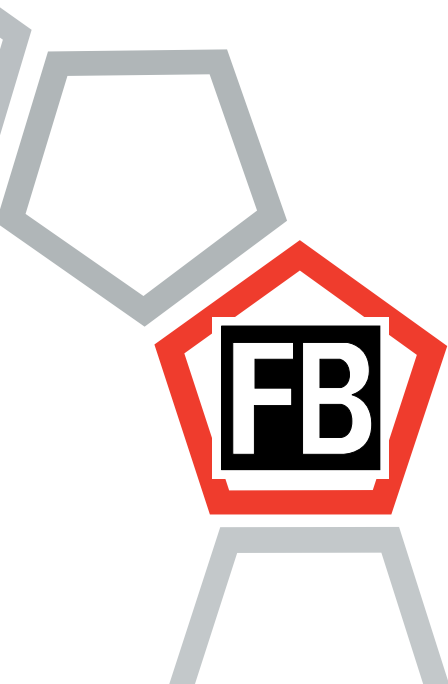
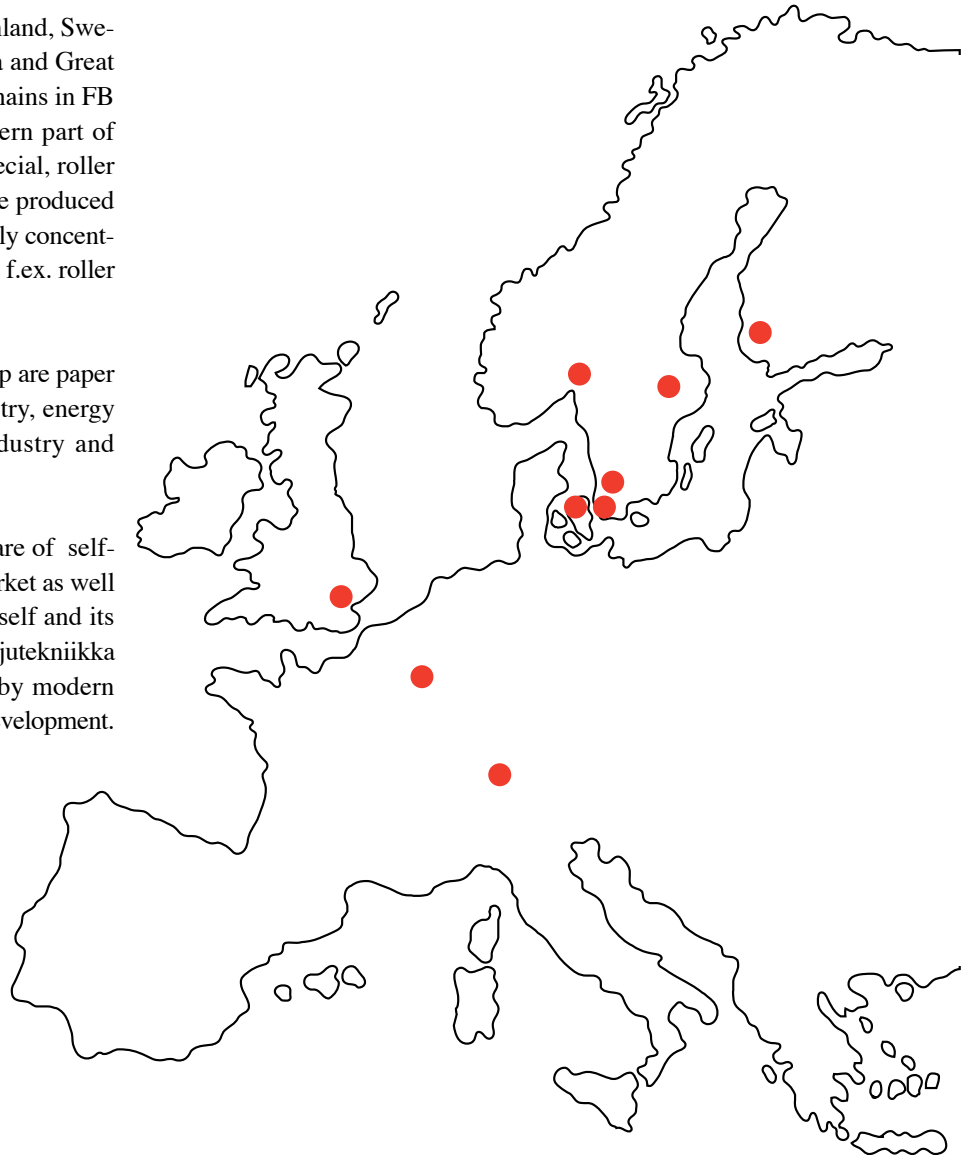

**Production and sales:**

# FB Ketjutekniikka Oy

**FIN-27710 Köyliö, FINLAND**

**phone + 358-2-540111 fax +358-2-540 1100**

**E-mail: [fb@fbketjutekniikka.fi](mailto:fb@fbketjutekniikka.fi)**

**SUPPLY SERVICES LTD**   
Phone 0800 102 112 - [www.supplyservices.co.nz](http://www.supplyservices.co.nz)